

PYD

ELECTROBOMBAS

SERIE

KS

DE ACHIQUE

SEWAGE PUMPS

POMPES DE RELEVAGE



CATÁLOGO TÉCNICO

TECHNICAL CATALOGUE

CATALOGUE TECHNIQUE

1. DESCRIPCIÓN DESCRIPTION DESCRIPTION

Bomba de achique con carcasa de acero inoxidable y fundición de hierro para dotarlas de gran durabilidad. Alta profundidad de inmersión gracias a su cierre mecánico resistente a altas presiones. Impulsor semiabierto de aleación de alto contenido en cromo y recubrimiento antiabrasión para alargar la vida útil.

✳ Drainage pump with stainless steel casing and cast iron construction to provide great durability. High immersion depth thanks to its mechanical seal resistant to high pressures. Semi-open impeller made of high chromium content alloy and anti-abrasion coating to extend the service life.

🇫🇷 Pompe de drainage avec boîtier en acier inoxydable et construction en fonte pour offrir une grande durabilité. Profondeur d'immersion élevée grâce à son joint mécanique résistant aux hautes pressions. Turbine semi-ouverte en alliage à haute teneur en chrome et revêtement anti-abrasion pour prolonger la durée de vie.



MATERIALES

Cuerpo de bomba: Acero INOX
Rejilla: Acero INOX
Cuerpo de expulsión: Fundición
Impulsor: Aleación de cromo con recubrimiento antiabrasión en hierro dúctil
Cierre mecánico: Cer-Sic/Carb-Cer

✳ MATERIALS

Pump body: Stainless steel
Grille: Stainless steel
Discharge body: Cast iron
Impeller: Chromium alloy with anti-abrasion coating in ductile iron
Mechanical seal: Cer-Sic/Carb-Cer

🇫🇷 MATÉRIELS

Corps de pompe : Acier inoxydable
Grille : Acier inoxydable
Corps de refoulement : Fonte
Turbine : Alliage de chrome avec revêtement anti-abrasion en fonte ductile
Joint mécanique : Cer-Sic/Carb-Cer

ÁREA DE TRABAJO

Temperatura máx. del líquido: 40°C
Grado de protección: IP68
Profundidad máx. de inmersión: 25 m
Aislamiento clase: F

✳ WORKING RANGE

Maximum liquid temperature: 40°C
Protection class: IP68
Max. immersion depth: 25 m
Insulation class: F

🇫🇷 PLAGUE DE TRAVAIL

Température maximale du liquide: 40°C
Classe de protection: IP68
Profondeur max. d'immersion: 25 m
Classe d'isolation: F

2. CURVAS CURVES COURBES

50 Hz n= 2890 min

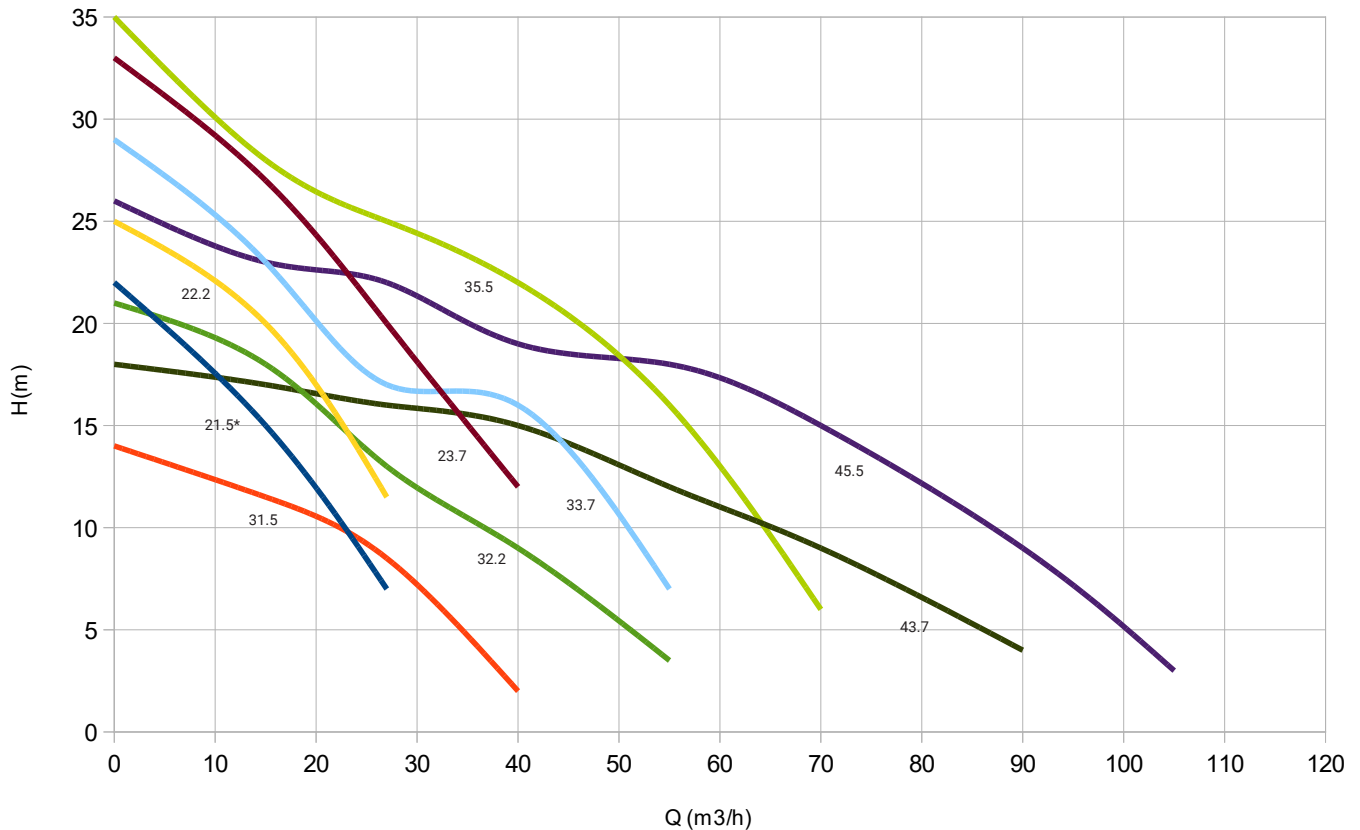

MODELO MODEL MODÈLE	P ₂		DN	CONSUMO (A)		SÓLIDOS mm	PESO Kg	CAUDAL FLOW DÉBIT							
	kW	Hp		220V	380V			m ³ /h	0	15	27	40	55	70	90
KSM21.5*	1,5	2,0	50	10	-	8,5	37,0	ALTIMETRO							
KS31.5	1,5	2,0	80	-	3,5	8,5	37,0	ALTIMETRO							
KS22.2	2,2	3,0	50	-	5,0	8,5	40,0	ALTIMETRO							
KS32.2	2,2	3,0	80	-	5,0	8,5	40,0	ALTIMETRO							
KS23.7	3,7	5,0	50	-	7,7	8,5	58,0	ALTIMETRO							
KS33.7	3,7	5,0	80	-	7,7	8,5	58,0	ALTIMETRO							
KS43.7	3,7	5,0	100	-	7,7	8,5	59,0	ALTIMETRO							
KS35.5	5,5	7,5	80	-	11,4	8,5	66,0	ALTIMETRO							
KS45.5	5,5	7,5	100	-	11,4	8,5	67,0	ALTIMETRO							

LÍNEA	ALTIMETRO			ALTIMETRO			ALTIMETRO		
	ALTIMETRO	ALTIMETRO	ALTIMETRO	ALTIMETRO	ALTIMETRO	ALTIMETRO	ALTIMETRO	ALTIMETRO	ALTIMETRO
22	15	7							
14	11,5	8,5	2						
25	20	11,5							
21	18	13	9	3,5					
33	27	20	12						
29	23	17	16	7					
18	17	16	15	12	9	4			
35	28	25	22	16	6				
26	23	22	19	18	15	9	3		

3. MEDIDAS MEASURES MESURES

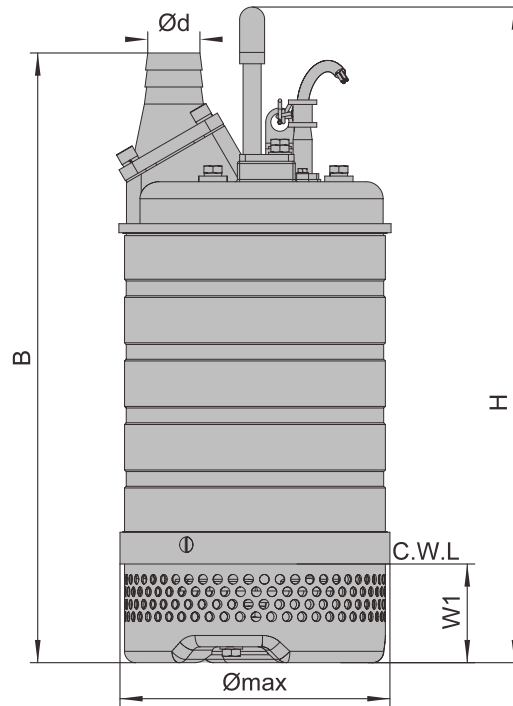

B: La altura de la parte inferior de la bomba a la salida.
H: La altura de la parte inferior de la bomba a la parte superior del mango.

MODELO MODEL MODÈLE	H	B	Ømax	W1
KSM21.5*	582	560	240	87
KS31.5	563	547	240	87
KS22.2	563	540	240	87
KS32.2	563	547	240	87
KS23.7	515	591	300	76
KS33.7	515	591	300	76
KS43.7	515	616	300	76
KS35.5	555	631	300	76
KS45.5	555	656	300	76

(*) KSM21.5 modelo monofásico. Resto de modelos en trifásico.

4. DESPIECE SPARE PARTS PIÈCES DE RECHANGE

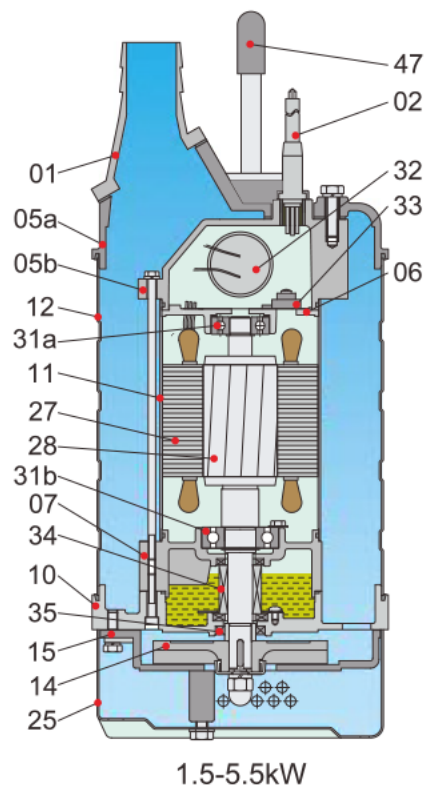
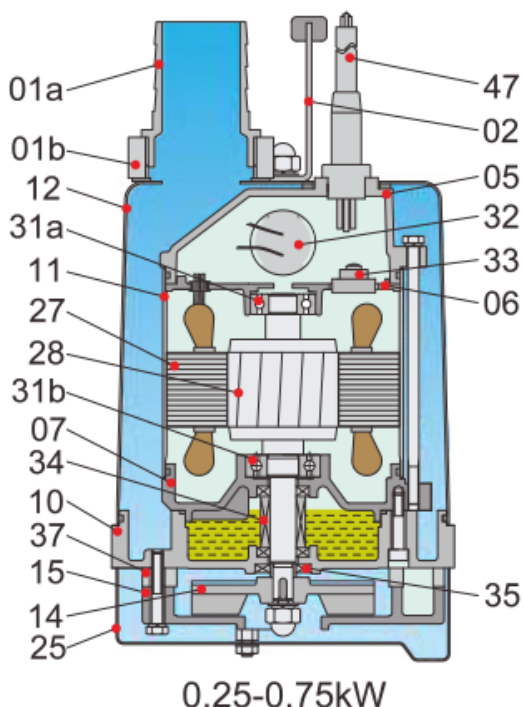

Nº	Nombre	Material
01A	Acoplamiento de manguera	ABS
01B	Acoplamiento de manguera	PA66
02	Asa	Caucho y AISI304
05*	Tapa superior	Hierro fundido
06	Cámara de rodamiento	Fundición de aluminio
07*	Cámara rodante	Hierro fundido
10	Cámara de sellado	Hierro fundido
11	Carcasa del motor	AISI 304
12	Cubierta exterior	AISI 304
14*	Impulsor	Hierro dúctil
15	Difusor	Hierro fundido
25	Rejilla	AISI 304
27	Estator	-
28	Rotor	Eje en AISI 304
31A	Cojinete	Rodamiento de bolas
31B	Cojinete	Rodamiento de bolas
32	Condensador	
33	Protector del motor	
34	Sello mecánico	Cer/Sic/Cer/Carb
35	Sello del aceite	-
37	Empaquetadora	NBR
47	Cable	H07RN-F

* Opcional AISI304SS

Nº	Nombre	Material
01*	Acoplamiento de manguera	Hierro fundido
02*	Asa	Caucho y acero
05A*	Tapa superior	Hierro fundido
05B*	Tapa superior	Hierro fundido
06	Cámara de rodamiento	Hierro fundido
07*	Cámara rodante	Hierro fundido
10*	Soporte del sello	Hierro fundido
11	Carcasa del motor	Acero INOX
12	Cubierta exterior	AISI 304
14*	Impulsor	Aleación de cromo alto
15*	Difusor	Hierro dúctil
25*	Rejilla	Acero
27	Estator	-
28	Rotor	AISI 420
31A	Cojinete	Rodamiento de bolas
31B	Cojinete	Rodamiento de bolas
32	Condensador	(solo monofásico)
33	Protector del motor	
34	Sello mecánico	Sic-Sic/Carbon-Sic (<2.2 kW) Sic-Sic/Sic-Sic (3.7-5.5kW)
35	Sello del aceite	-
47	Cable	H07RN-F

* Opcional AISI304SS

4. DESPIECE SPARE PARTS PIÈCES DE RECHANGE

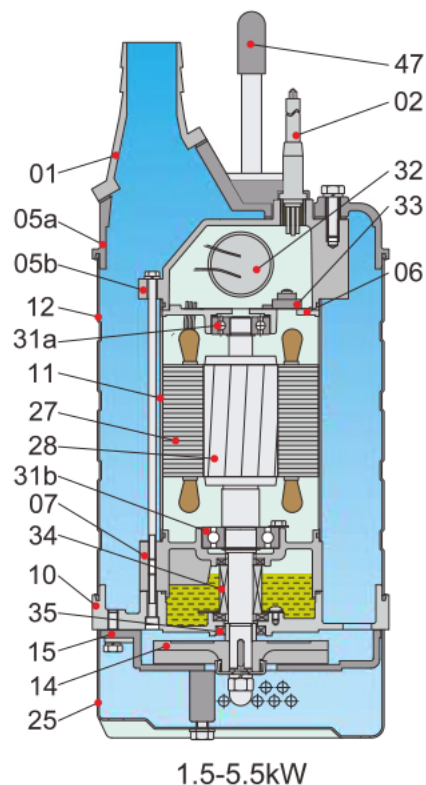
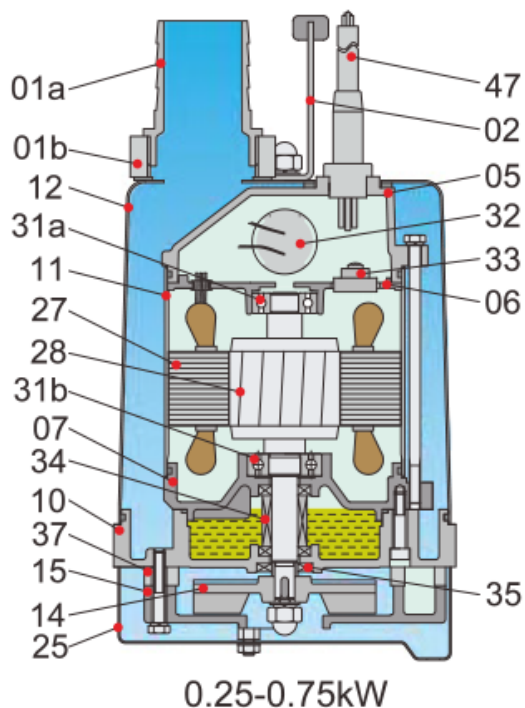

N°	Name	Material
01A	Hose coupling	ABS
01B	Hose coupling	PA66
02	Handle	Rubber y AISI304
05*	Upper cover	Cast iron
06	Up-bearing house	Aluminum die casting
07*	Bearing house	Cast iron
10	Seal house	Cast iron
11	Motor casing	AISI 304
12	Outer casing	AISI 304
14*	Impeller	Ductile iron
15	Diffuser	Cast iron
25	Strainer	AISI 304
27	Stator	-
28	Rotor	Shaft: AISI 304
31A	Bearing	Ball bearing
31B	Bearing	Ball bearing
32	Capacitor	
33	Motor protector	
34	Mechanical seal	Cer/Sic/Cer/Carb
35	Oil seal	-
37	Gasket	NBR
47	Cable	H07RN-F

N°	Name	Material
01*	Hose coupling	Cast iron
02*	Handle	Rubber and steel
05A*	Upper cover	Cast iron
05B*	Upper cover	Cast iron
06	Up-bearing house	Cast iron
07*	Bearing house	Cast iron
10*	Seal bracket	Cast iron
11	Motor casing	Stainless steel
12	Outer casing	AISI 304
14*	Impeller	High chrome alloy
15*	Diffuser	Ductile iron
25*	Strainer	Steel
27	Stator	-
28	Rotor	AISI 420
31A	Bearing	Ball bearing
31B	Bearing	Ball bearing
32	Capacitor	Single phase only
33	Motor protector	
34	Mechanical seal	Sic-Sic/Carbon-Sic (<2.2 kW) Sic-Sic/Sic-Sic (3.7-5.5kW)
35	Oil seal	-
47	Cable	H07RN-F

4. DESPIECE SPARE PARTS PIÈCES DE RECHANGE

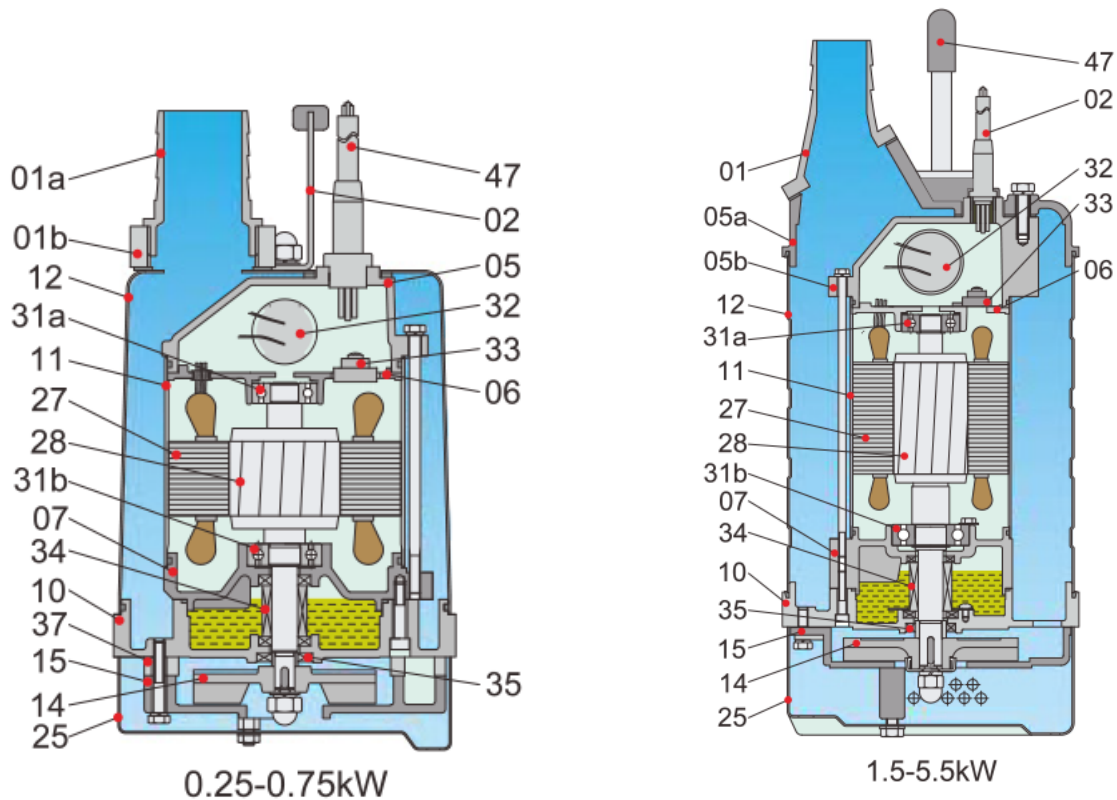

N°	Nom	Matériel
01A	Raccord de tuyau	ABS
01B	Raccord de tuyau	PA66
02	Poignée	Caoutchouc et AISI304
05*	Couvercle supérieur	Fonte
06	Boîtier de palier supérieur	Moulage sous pression d'aluminium
07*	Logement de roulement	Fonte
10	Logement du joint d'étanchéité	Fonte
11	Carter de moteur	AISI 304
12	Carter externe	AISI 304
14*	Roue	Fonte ductile
15	Diffuseur	Fonte
25	Passoire	AISI 304
27	Stator	-
28	Rotor	Arbre: AISI 304
31A	Roulement	Roulement à billes
31B	Roulement	Roulement à billes
32	Condensateur	
33	Motor protecteur	
34	Garniture mécanique	Cer/Sic/Cer/Carb
35	Joint d'huile	-
37	Joint d'étanchéité	NBR
47	Câble	H07RN-F

N°	Nom	Matériel
01*	Raccord de tuyau	Fonte
02*	Poignée	Caoutchouc et steel
05A*	Couvercle supérieur	Fonte
05B*	Couvercle supérieur	Fonte
06	Boîtier de palier supérieur	Fonte
07*	Boîtier de roulement	Fonte
10*	Support de joint d'étanchéité	Fonte
11	Carter moteur	Acier inoxydable
12	Carter externe	AISI 304
14*	Roue	Alliage à haute teneur en chrome
15*	Diffuseur	Fonte ductile
25*	Passoire	Acier
27	Stator	-
28	Rotor	AISI 420
31A	Roulement	Roulement à billes
31B	Roulement	Roulement à billes
32	Condensateur	Uniquement monophasé
33	Motor protecteur	
34	Garniture mécanique	Sic-Sic/Carbon-Sic (<2.2 kW) Sic-Sic/Sic-Sic (3.7-5.5kW)
35	Joint d'huile	-
47	Câble	H07RN-F

Proindecsa

C/ Paraguay, parc. 13-5/6
Polígono industrial Oeste
30820 Alcantarilla, Murcia (Spain)

Tel. : +34 968 880 852
proindecsa@proindecsa.com

www.proindecsa.com



🇪🇺 Proindecsa S.L. no se hace responsable de los posibles errores u omisiones que pueda contener este catálogo, ni de los daños o perjuicios que puedan derivarse de su uso. Proindecsa S.L. se reserva el derecho de modificar o actualizar el contenido de este catálogo en cualquier momento y sin previo aviso.

✳️ Proindecsa S.L. shall not be liable for any errors or omissions that this catalogue may contain, nor for any damages that may arise from its use. Proindecsa S.L. reserves the right to modify or update the contents of this catalogue at any time and without prior notice.

