

PYD

ELECTROBOMBAS

SERIES

R31 & R25

DEPÓSITOS DE POLIETILENO

POLYETHYLENE TANKS

RÉSERVOIRS EN POLYÉTHYLÈNE



CATÁLOGO TÉCNICO

TECHNICAL CATALOGUE

CATALOGUE TECHNIQUE

1. DESCRIPCIÓN DESCRIPTION DESCRIPTION

Serie R25



CARACTERÍSTICAS

- Polietileno lineal aditivado anti-UV.
- Calidad alimentaria (registro sanitario)
- Color estándar natural translúcido
- Encajables en vacío, un 50% de su volúmen.

CHARACTERISTICS

- Linear polyethylene with anti-UV additives.
- Food quality (sanitary registration)
- Standard natural translucent colour
- Vacuum packable, 50% of their volume.

CARACTÉRISTIQUES

- Polyéthylène linéaire avec additifs anti-UV.
- Qualité alimentaire (enregistrement sanitaire)
- Couleur naturelle translucide standard
- Emballage sous vide, 50% de leur volume.

2. DIMENSIONES DIMENSIONS DIMENSIONS

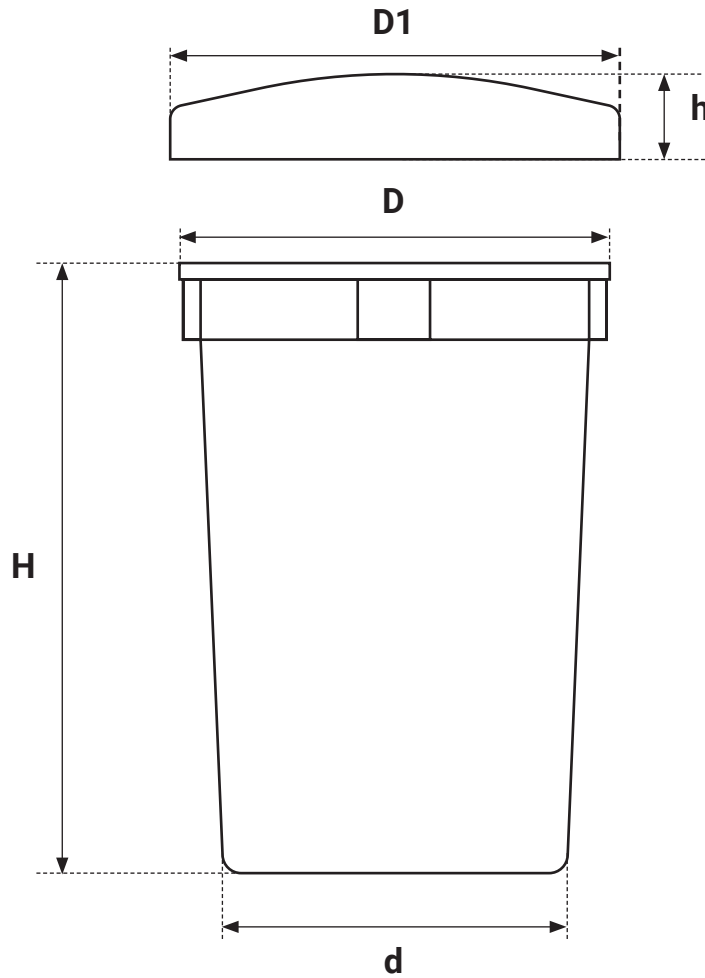

MODELO MODEL MODÈLE	CAPACIDAD CAPACITY CAPACITÉ	D	d	H	D1	h
	L	mm	mm	mm	mm	mm
R250200	200	650	500	890	670	130
R250500	500	880	720	1100	920	145
R251000	1000	1170	960	1310	1200	160
R251500	1500		1400	1130	-	-
R252000	2000	1715	1500	1150	1750	150
R253000	3000	1840	1640	1440	1880	230

1. DESCRIPCIÓN DESCRIPTION DESCRIPTION

Serie R31



CARACTERÍSTICAS

- Polietileno lineal aditivado anti-UV.
- Calidad alimentaria (registro sanitario)
- Color estándar natural translúcido
- Dispone de tapa roscada e indicaciones de nivel de líquido.
- Zona superior reforzada mediante nervio.
- Gran rigidez para montaje de agitadores y bombas dosificadoras.
- Entrantes verticales para mejorar la mezcla.

CHARACTERISTICS

- Linear polyethylene with anti-UV additives.
- Food quality (sanitary registration)
- Standard natural translucent colour
- With threaded lid and liquid level indications.
- Upper area reinforced by ribbing.
- High rigidity for mounting agitators and dosing pumps.
- Vertical inlets for improved mixing.

CARACTÉRISTIQUES

- Polyéthylène linéaire avec additifs anti-UV.
- Qualité alimentaire (enregistrement sanitaire)
- Couleur standard naturel translucide
- Avec bouchon à vis et indication du niveau de liquide.
- Zone supérieure renforcée par des nervures.
- Grande rigidité pour le montage d'agitateurs et de pompes doseuses.
- Entrées verticales pour un meilleur mélange.

2. DIMENSIONES DIMENSIONS DIMENSIONS

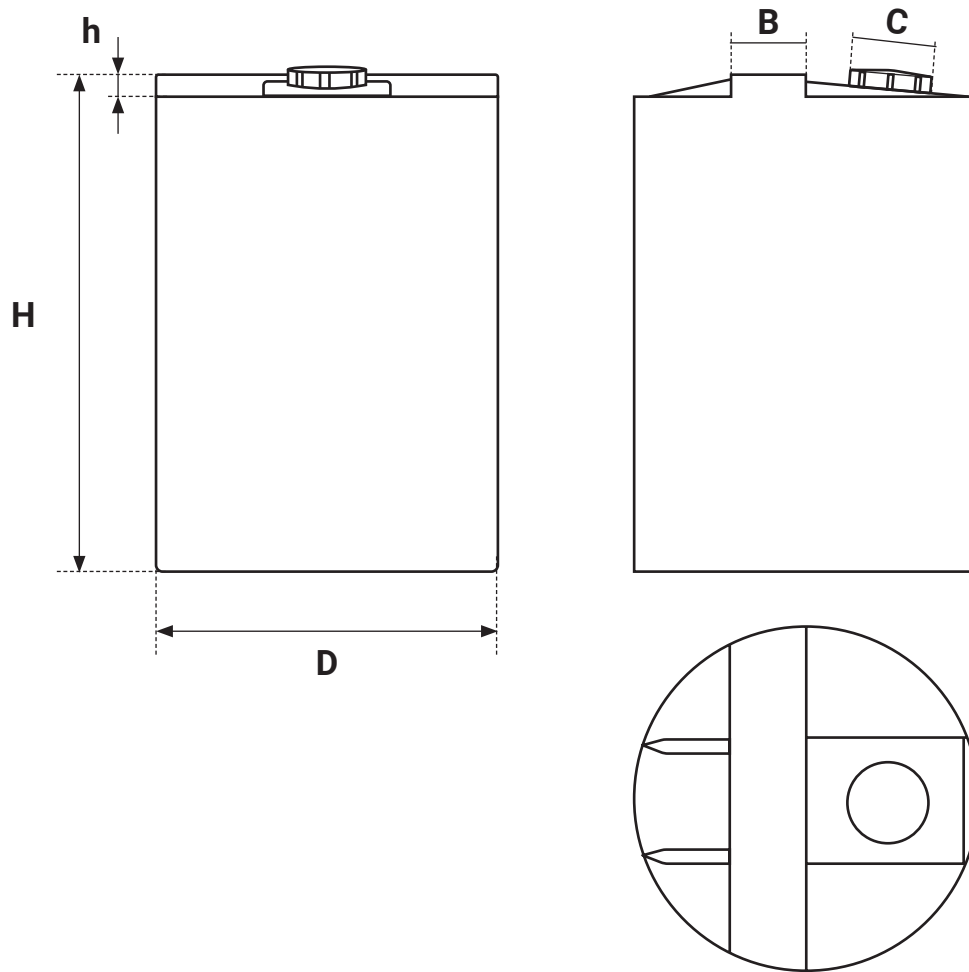

MODELO MODEL MODÈLE	CAPACIDAD CAPACITY CAPACITÉ	D	H	h	B	C
	L					
		mm	mm	mm	mm	mm
R310050	50	375	680	180	180	150
R310100	100	475	655	34	230	159
R310230	230	575	945	65	160	225
R310335	335	652	1124	65	165	225
R310580	580	790	1215	65	200	275
R311050	1050	995	1450	65	230	275

Proindecsa

C/ Paraguay, parc. 13-5/6
Polígono industrial Oeste
30820 Alcantarilla, Murcia (Spain)

Tel. : +34 968 880 852
proindecsa@proindecsa.com

www.proindecsa.com



🇪🇸 Proindecsa S.L. no se hace responsable de los posibles errores u omisiones que pueda contener este catálogo, ni de los daños o perjuicios que puedan derivarse de su uso. Proindecsa S.L. se reserva el derecho de modificar o actualizar el contenido de este catálogo en cualquier momento y sin previo aviso.

✳️ Proindecsa S.L. shall not be liable for any errors or omissions that this catalogue may contain, nor for any damages that may arise from its use. Proindecsa S.L. reserves the right to modify or update the contents of this catalogue at any time and without prior notice.

