

PYD

ELECTROBOMBAS

SERIE

V

BOMBA DE ACHIQUE SUMERGIBLE

SUBMERSIBLE DEWATERING PUMP

POMPE SUBMERSIBLE D'ASSÈCHEMENT



CATÁLOGO TÉCNICO

TECHNICAL CATALOGUE

CATALOGUE TECHNIQUE

1. DESCRIPCIÓN DESCRIPTION DESCRIPTION

Bomba de achique para uso doméstico, de construcción robusta y provista de cierre mecánico. Indicada para el vaciado de arquetas, fosas sépticas, aguas residuales, etc. Completamente de material anticorrosivo; están dotadas de inserción de latón en la boca de impulsión.

- ✦ Drain pump for home use, robust and equipped with mechanical seal construction. Suitable for emptying arquetas, septic tanks, sewage, etc. Strongly corrosive material; they are fitted with brass insert in the discharge port.

Pompe de vidange pour un usage domestique, robuste et équipé de la construction de la garniture mécanique.

- 🇫🇷 Convient pour arquetas vidange, fosse septique, assainissement, etc. Matériau fortement corrosive; ils sont équipés avec insert en laiton dans l'orifice de décharge.

**V450
V750**



V1100



MATERIALES

Cuerpo aspiración: Fundición
Cuerpo impulsión: Fundición
Impulsor: Fundición
Difusor: Fundición
Eje rotor: INOX 304
Envolvente: INOX 304
Cierre mecánico: Cer/Graf
Rejilla aspiración: INOX 304
Tornillería: INOX 304

✦ MATERIALS

Suction body: Cast iron
Discharge body: Cast iron
Impeller: Cast iron
Diffuser: Cast iron
Rotor shaft: Stainless Steel 304
Casing: Stainless Steel 304
Mechanical seal: Cer/Graf
Intake grille: Stainless Steel 304
Screws: Stainless Steel 304

🇫🇷 MATÉRIELS

Corps d'aspiration : Fonte
Corps de refoulement : Fonte
Roue : Fonte
Diffuseur : Fonte
Arbre du rotor : Acier inoxydable 304
Boîtier : Acier inoxydable 304
Garniture mécanique : Cer/Graf
Grille d'admission : Acier inoxydable 304
Vis : Acier inoxydable 304

ÁREA DE TRABAJO

Temperatura máx. del líquido: 35°C
Grado de protección: IP68
Aislamiento: F
Inmersión máx.: 5 m
Fluidos: Agua sucia

✦ WORKING RANGE

Max. liquid temperature: 35°C
Degree of protection: IP68
Insulation: F
Max. immersion: 5 m
Fluids: Dirty water

🇫🇷 PLAGUE DE TRAVAIL

Température maximale du liquide : 35°C
Degré de protection : IP68
Isolation : F
Immersion maximale : 5 m
Fluides : Eau sale

2. CURVAS CURVES COURBES

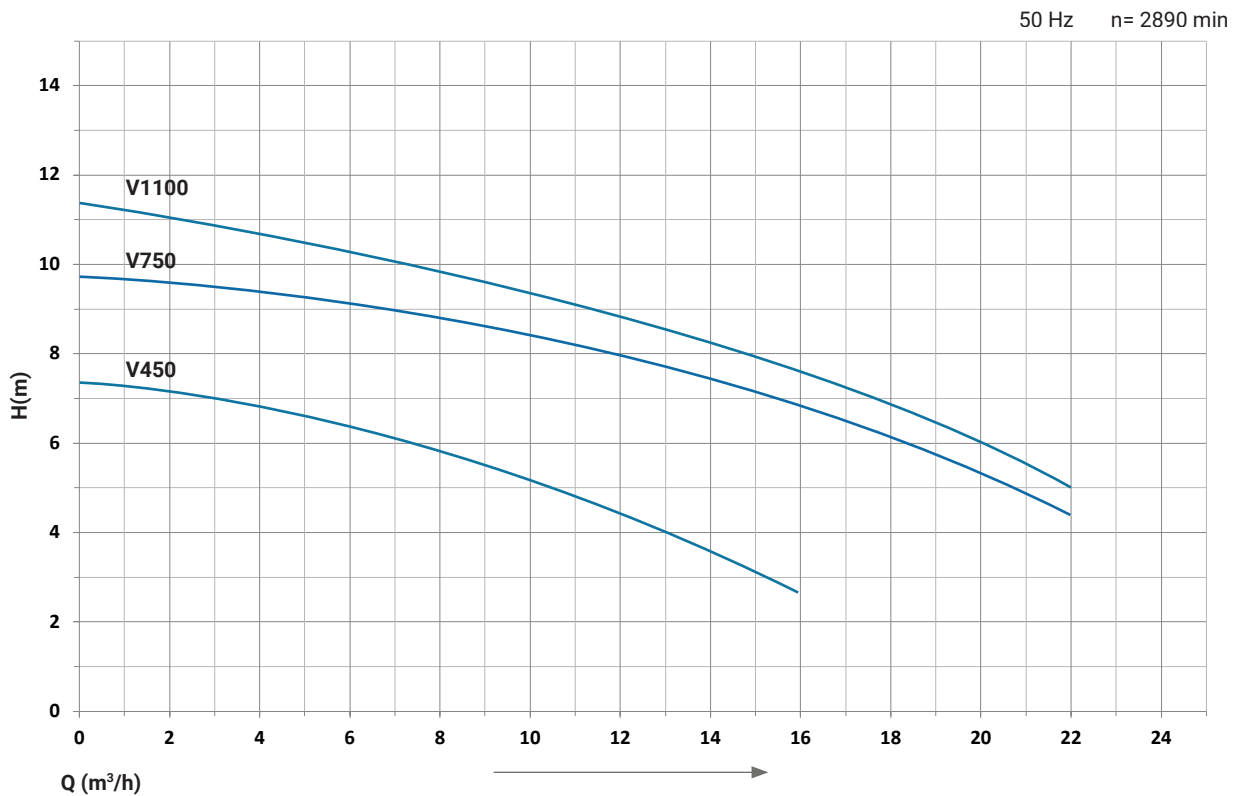

MODELO MODEL MODÈLE	CAUDAL FLOW DÉBIT									
	m ³ /h	0	2	4	8	12	16	18	20	22
	l/min	0	33	67	133	200	270	300	333	366
	ALTURA DE CARGA EN METROS			LOADING HEIGHT IN METRES			HAUTEUR DE CHARGEMENT EN MÈTRES			
V450		7,7	6,7	6,3	5,5	4,3	2,7			
V750		9,4	8,8	8,6	8,5	8,0	6,8	5,9	5,1	4,2
V1100		11,3	11,0	10,8	9,9	8,9	7,3	6,7	6,0	5,0

3. DATOS TÉCNICOS TECHNICAL DATA DONNÉES TECHNIQUES

MODELO MODEL MODÈLE	SALIDA OUTLET SORTIE [mm]	SÓLIDOS SOLIDS SOLIDES [mm]	POTENCIA (P ₂) POWER POUISSANCE		POTENCIA (P ₁) POWER POUISSANCE W	INTENSIDAD (A) CURRENT INTENSITÉ	
			KW	Hp		1~220	3~380
V450	50	25	0,45	0,60	550	4,3	-
V750	50	25	0,75	1,00	920	5,2	1,8
V1100	50	25	1,10	1,50	1.300	7,2	3,5

4. MEDIDAS MEASURES MESURES

V450

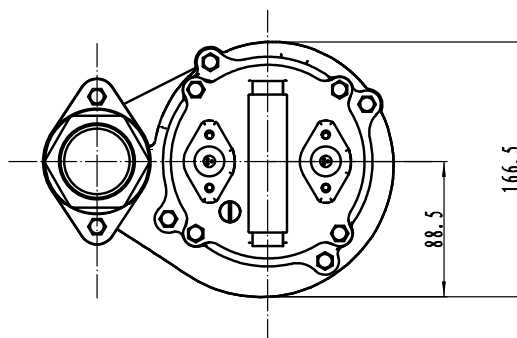
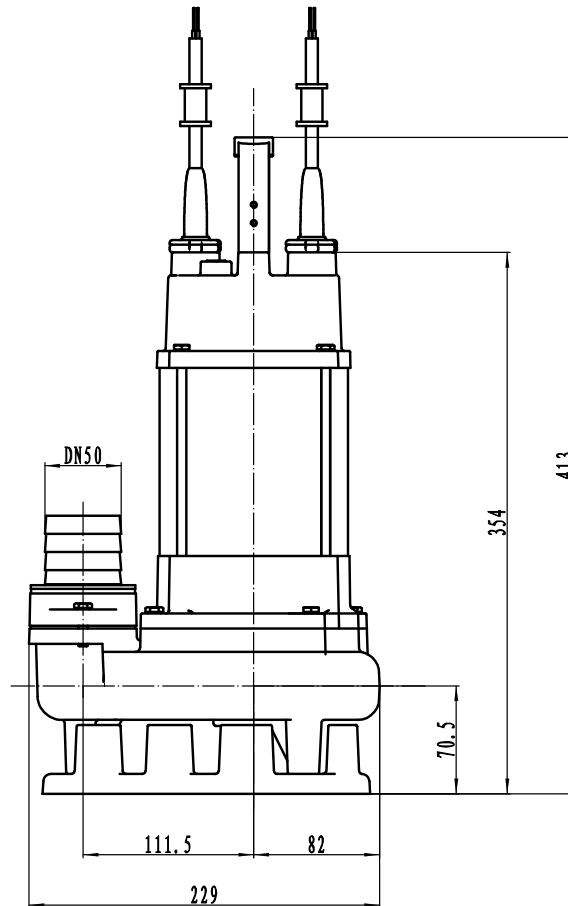

4. MEDIDAS MEASURES MESURES

V750

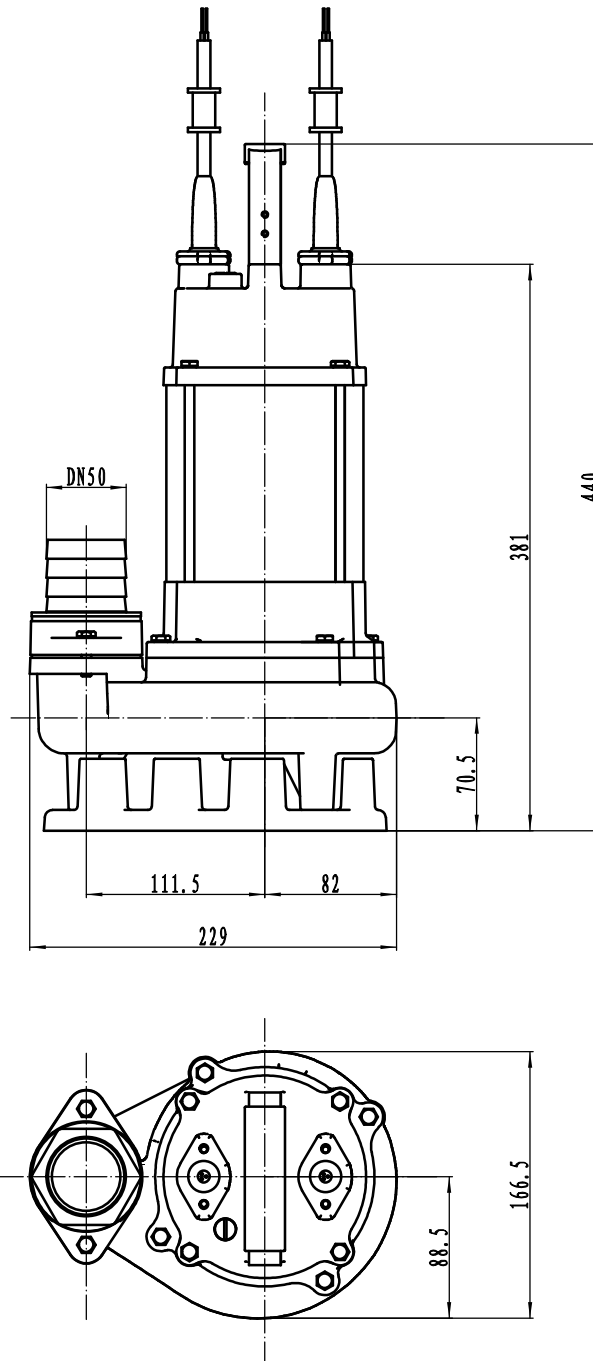

4. MEDIDAS MEASURES MESURES

V1100

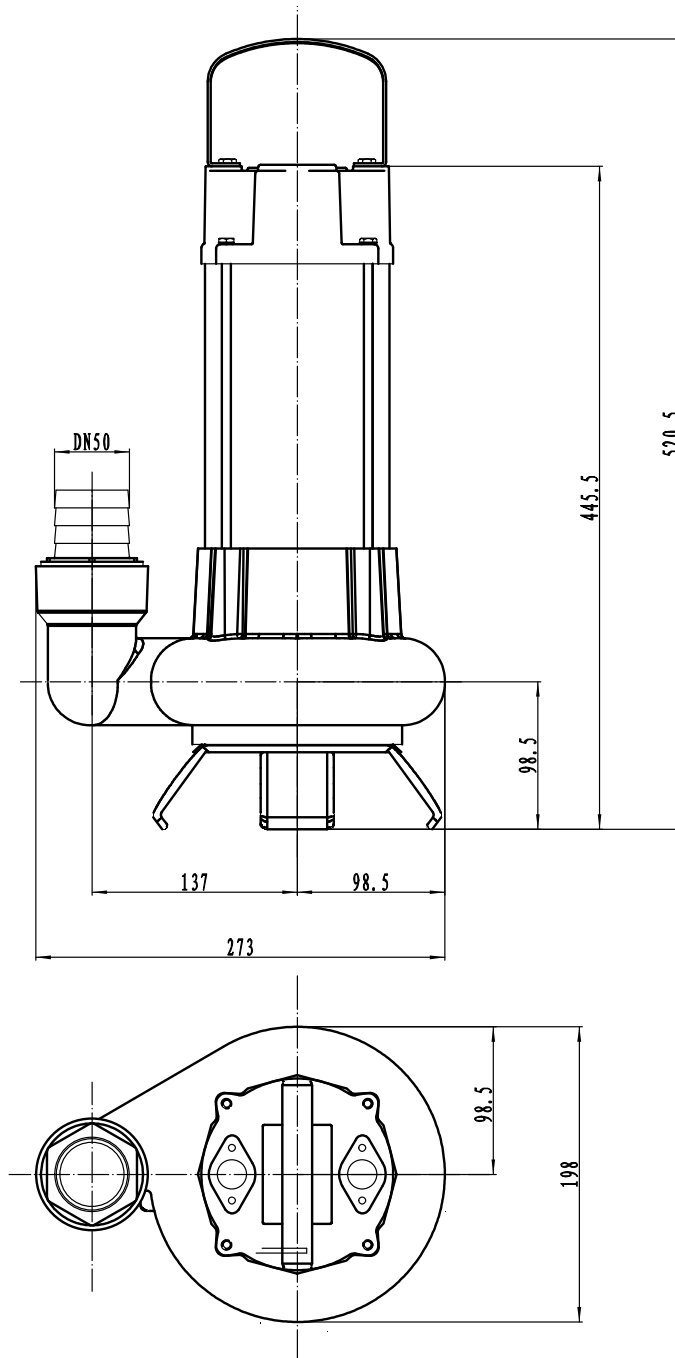

5. DESPIECE SPARE PARTS PIÈCES DE RECHANGE V450

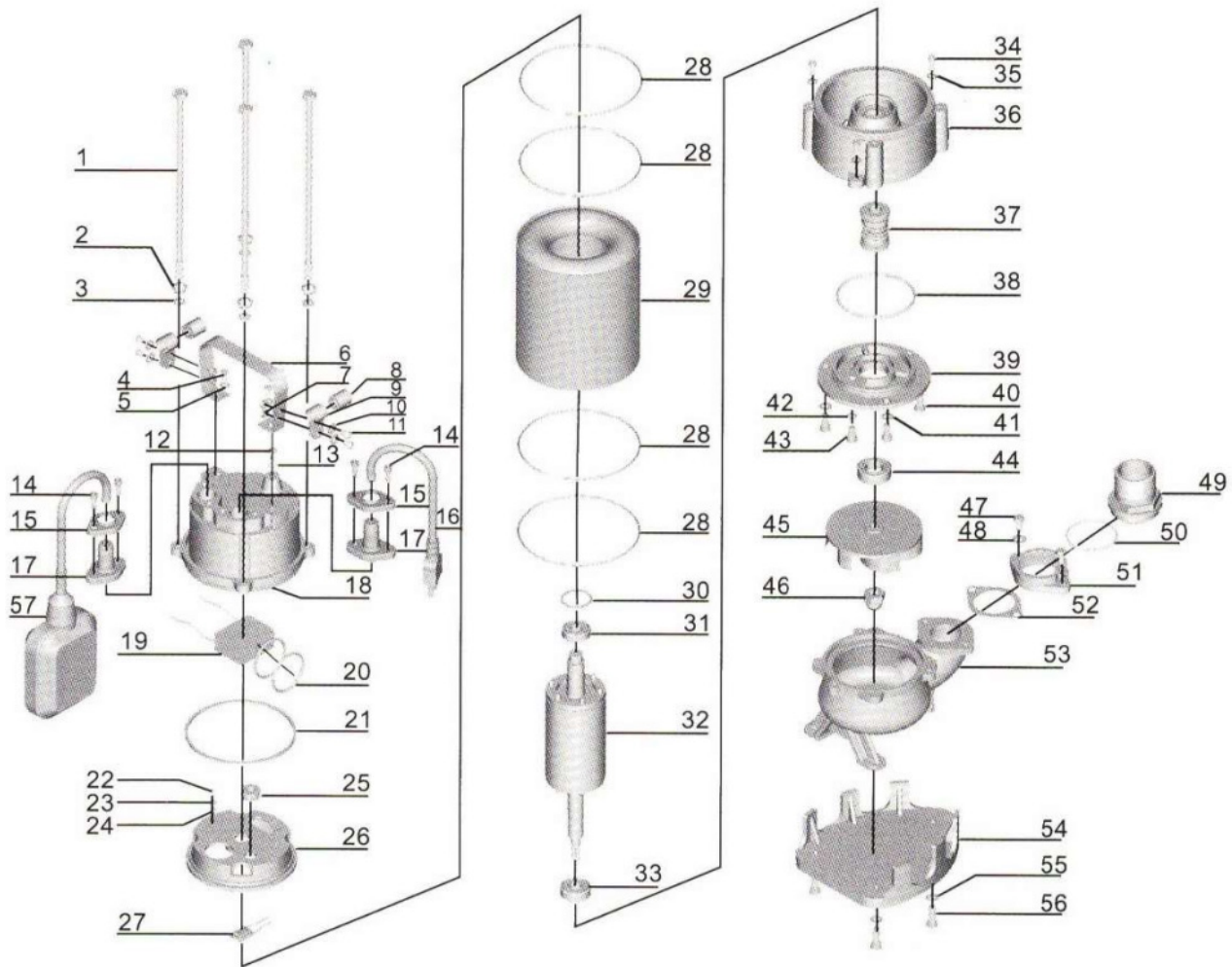

Nº	DESCRIPCIÓN	Nº	DESCRIPCIÓN	Nº	DESCRIPCIÓN	Nº	DESCRIPCIÓN
1	Barra	16	Cable	31	Rodamiento	46	Tuerca
2	Arandela extensible	17	Protector de cable	32	Rotor	47	Barra
3	Arandela	18	Cobertura de cable	33	Rodamiento	48	Arandela
4	Barra	19	Condensador	34	Tornillo	49	Conector de salida
5	Arandela	20	Anillo tórico	35	Arandela	50	Anillo tórico
6	Asa	21	Arandela de goma	36	Pieza de conexión	51	Tuerca de conexión
7	Tuerca	22	Tornillo	37	Cierre mecánico	52	Arandela de goma
8	Protector	23	Arandela extensible	38	Anillo tórico	53	Cuerpo de la bomba
9	Presor de cables	24	Arandela	39	Cobertura de la cámara de aceite	54	Placa base
10	Arandela	25	Protector de línea	40	Tornillo	55	Arandela
11	Tornillo	26	Cobertura del motor	41	Arandela	56	Tornillo
12	Barra	27	Protector termal	42	Anillo tórico	57	Interruptor de nivel
13	Anillo tórico	28	Anillo tórico	43	Tornillo		
14	Tornillo	29	Estátor	44	Sello de aceite		
15	Brida	30	Arandela ondulada	45	Impulsor		

5. DESPIECE PARTS PIÈCES V450

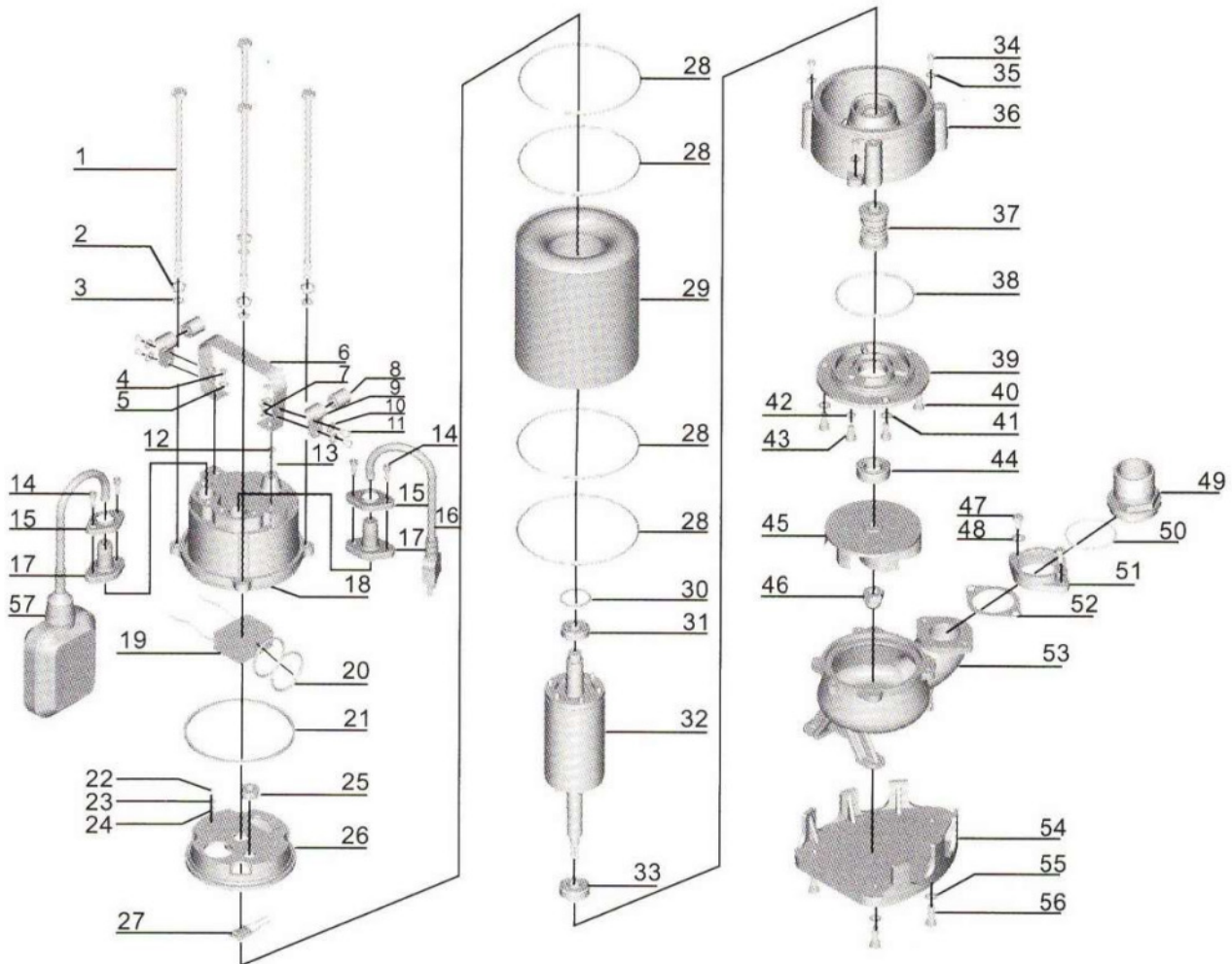

N°	DESCRIPTION	N°	DESCRIPTION	N°	DESCRIPTION	N°	DESCRIPTION
1	Blot	16	Cable	31	Bearing	46	Nut
2	Stretching washer	17	Cable protector	32	Rotor	47	Blot
3	Washer	18	Cable cover	33	Bearing	48	Washer
4	Blot	19	Capacitor	34	Screw	49	Outlet connector
5	Washer	20	"O" ring	35	Washer	50	"O" ring
6	Handle	21	Rubber washer	36	Connection part	51	Connection nut
7	Nut	22	Screw	37	Mechanical seal	52	Rubber washer
8	Protector	23	Stretching washer	38	"O" ring	53	Pump body
9	Cable presser	24	Washer	39	Oil chamber cover	54	Base plate
10	Washer	25	Line protector	40	Screw	55	Washer
11	Screw	26	Motor cover	41	Washer	56	Screw
12	Blot	27	Thermal protector	42	"O" ring	57	Float switch
13	"O" ring	28	"O" ring	43	Screw		
14	Screw	29	Stator	44	Oil seal		
15	Flange	30	Undulated washer	45	Impeller		

5. DESPIECE PARTS PIÈCES V450

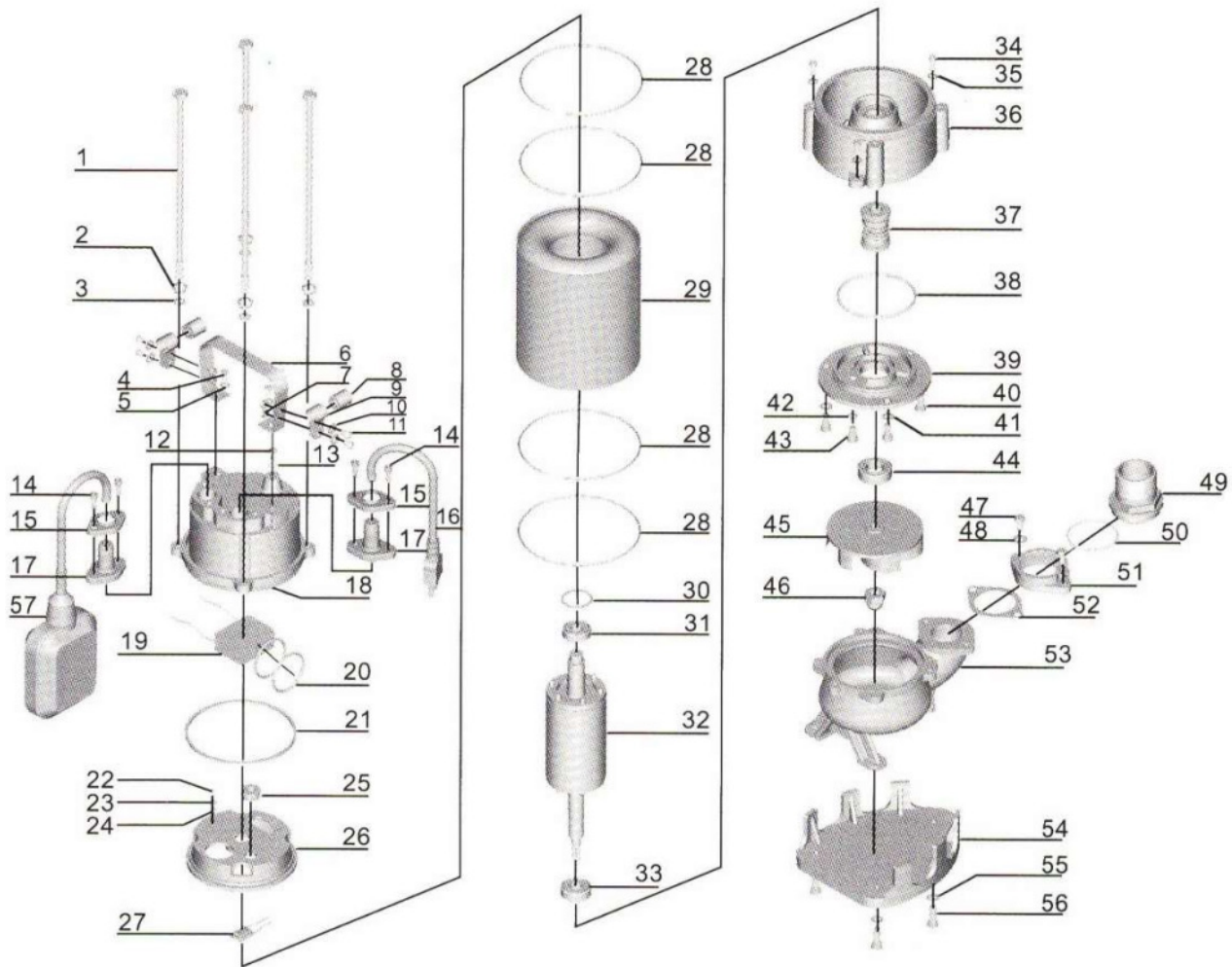

N°	DESCRIPTION	N°	DESCRIPTION	N°	DESCRIPTION	N°	DESCRIPTION
1	Tâche	16	Câble	31	Roulement	46	Écrou
2	Rondelle d'étirement	17	Protecteur de câble	32	Rotor	47	Tâche
3	Rondelle	18	Couverture de câble	33	Roulement	48	Rondelle
4	Tâche	19	Condensateur	34	Vis	49	Connecteur de sortie
5	Rondelle	20	Joint torique	35	Rondelle	50	Joint torique
6	Poignée	21	Rondelle en caoutchouc	36	Pièce de connexion	51	Écrou de connexion
7	Écrou	22	Vis	37	Garniture mécanique	52	Rondelle en caoutchouc
8	Protecteur	23	Rondelle d'étirement	38	Joint torique	53	Corps de pompe
9	Tendeur de câble	24	Rondelle	39	Couvercle de chambre à huile	54	Plaque de base
10	Rondelle	25	Protecteur de ligne	40	Vis	55	Rondelle
11	Vis	26	Couvercle de moteur	41	Rondelle	56	Vis
12	Tâche	27	Protecteur thermique	42	Joint torique	57	Interrupteur à flotteur
13	Joint torique	28	Joint torique	43	Vis		
14	Vis	29	Stator	44	Joint d'huile		
15	Collerette	30	Rondelle ondulée	45	Roue		

5. DESPIECE SPARE PARTS PIÈCES DE RECHANGE V750

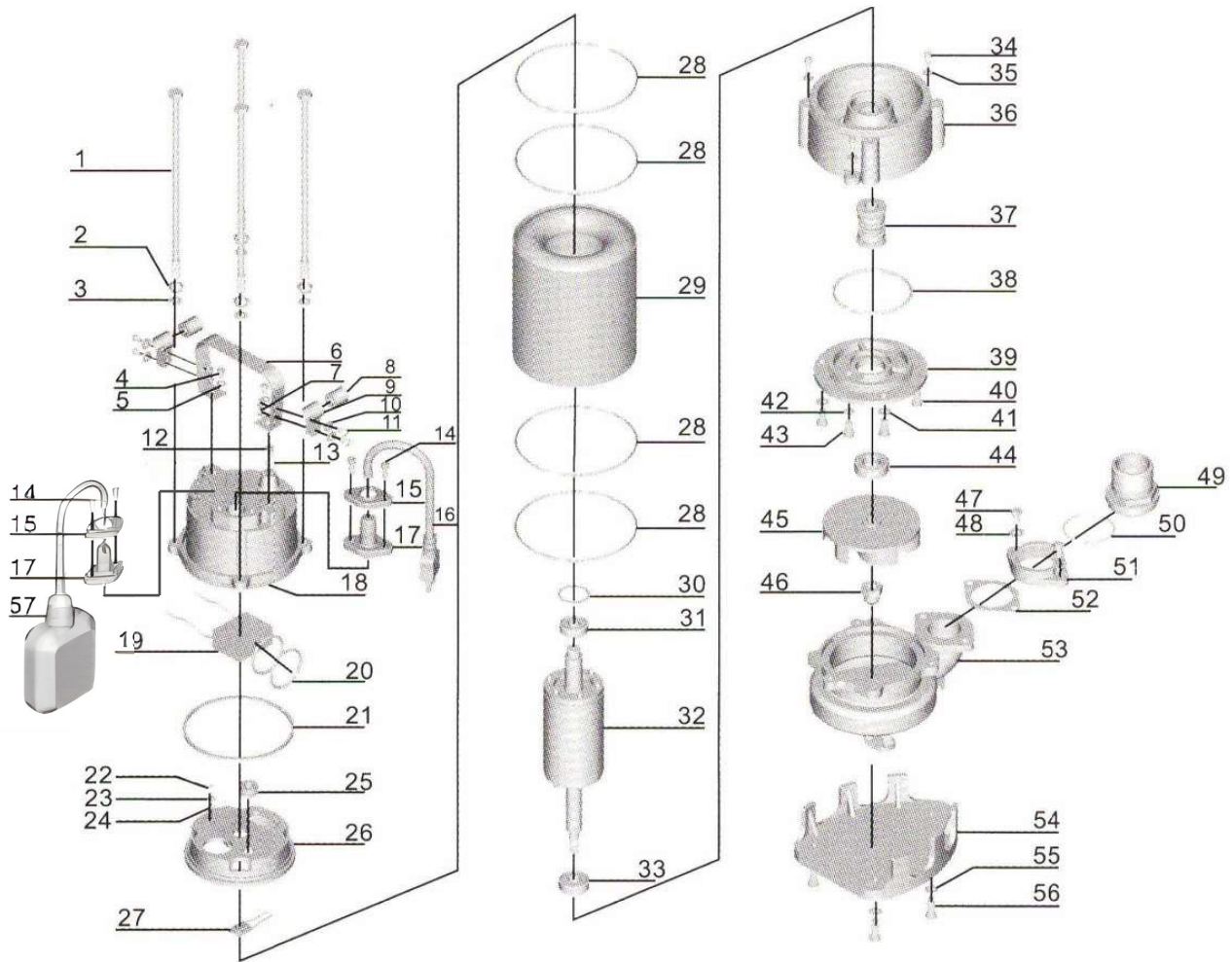

Nº	DESCRIPCIÓN	Nº	DESCRIPCIÓN	Nº	DESCRIPCIÓN	Nº	DESCRIPCIÓN
1	Barra	16	Cable	31	Rodamiento	46	Tuerca
2	Arandela extensible	17	Protector de cable	32	Rotor	47	Barra
3	Arandela	18	Cobertura del cable	33	Rodamiento	48	Arandela
4	Barra	19	Condensador	34	Tornillo	49	Conector de salida
5	Arandela	20	Anillo tórico	35	Arandela	50	Anillo tórico
6	Asa	21	Arandela de goma	36	Pieza de conexión	51	Tuerca de conexión
7	Tuerca	22	Tornillo	37	Cierre mecánico	52	Arandela de goma
8	Protector	23	Arandela extensible	38	Anillo tórico	53	Cuerpo de la bomba
9	Presor de cable	24	Arandela	39	Cobertura de la cámara de aceite	54	Placa base
10	Arandela	25	Protector de línea	40	Tornillo	55	Arandela
11	Tornillo	26	Cobertura del motor	41	Arandela	56	Tornillo
12	Tornillo	27	Protector termal	42	Anillo tórico	57	Interruptor de nivel
13	Anillo tórico	28	Anillo tórico	43	Tornillo		
14	Tornillo	29	Estátor	44	Sello de aceite		
15	Brida	30	Arandela ondulada	45	Impulsor		

5. DESPIECE SPARE PARTS PIÈCES DE RECHANGE V750

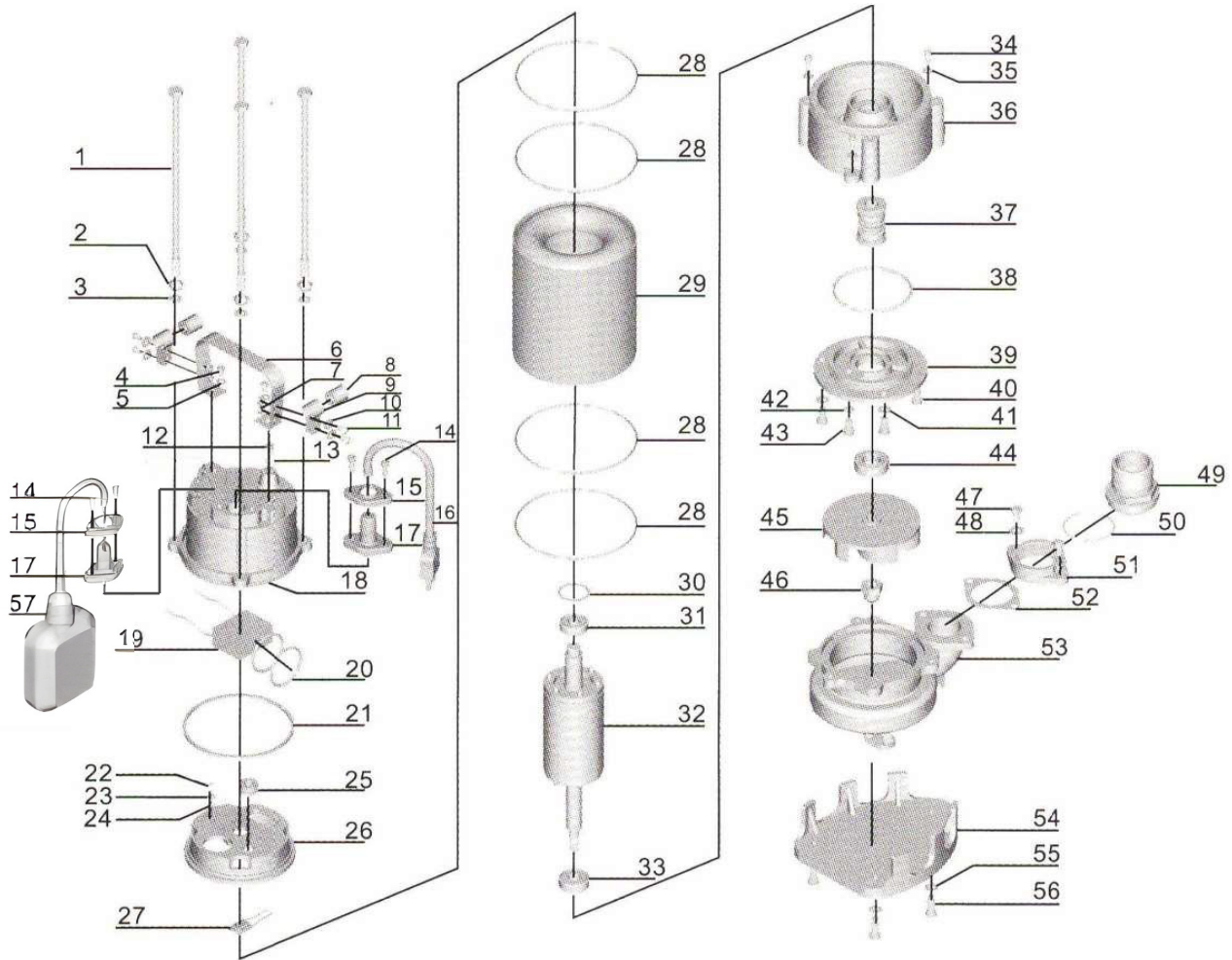

N°	DESCRIPTION	N°	DESCRIPTION	N°	DESCRIPTION	N°	DESCRIPTION
1	Blot	16	Cable	31	Bearing	46	Nut
2	Stretching washer	17	Cable protector	32	Rotor	47	Blot
3	Washer	18	Cable cover	33	Bearing	48	Washer
4	Blot	19	Capacitor	34	Screw	49	Outlet connector
5	Washer	20	"O" ring	35	Washer	50	"O" ring
6	Hangle	21	Rubber washer	36	Connection part	51	Connection nut
7	Nut	22	Screw	37	Mechanical seal	52	Rubber washer
8	Protector	23	Stretching washer	38	"O" ring	53	Pump body
9	Cable presser	24	Washer	39	Oil chamber cover	54	Base plate
10	Washer	25	Line protector	40	Screw	55	Washer
11	Screw	26	Motor cover	41	Washer	56	Screw
12	Blot	27	Thermal protector	42	"O" ring	57	Float switch
13	"O" ring	28	"O" ring	43	Screw		
14	Screw	29	Stator	44	Oil seal		
15	Flange	30	Undulated washer	45	Impeller		

5. DESPIECE SPARE PARTS PIÈCES DE RECHANGE V750

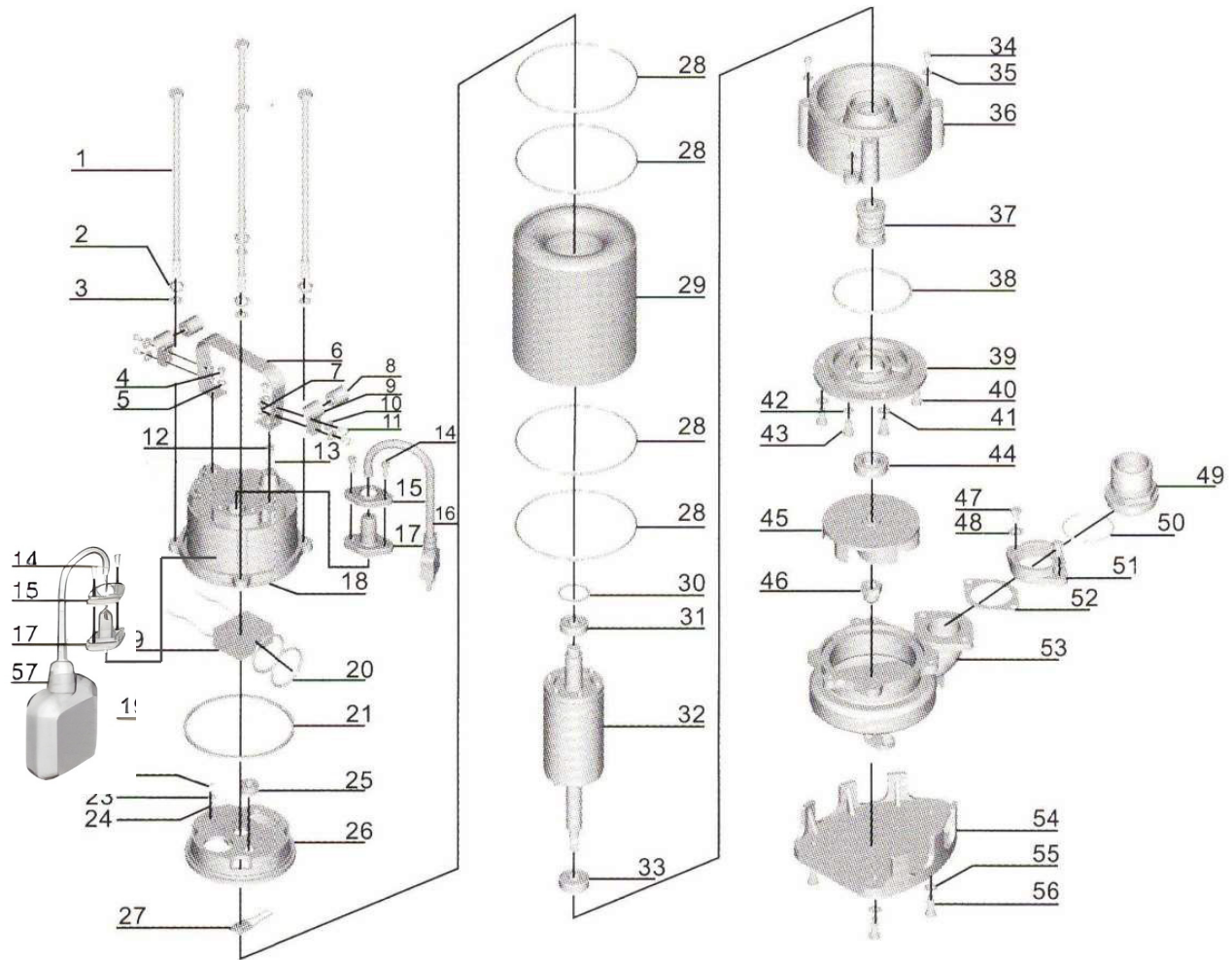

N°	DESCRIPTION	N°	DESCRIPTION	N°	DESCRIPTION	N°	DESCRIPTION
1	Tâche	16	Câble	31	Roulement	46	Écrou
2	Rondelle d'étirement	17	Protecteur de câble	32	Rotor	47	Tâche
3	Rondelle	18	Couvercle de câble	33	Roulement	48	Rondelle
4	Tâche	19	Condensateur	34	Vis	49	Connecteur de sortie
5	Rondelle	20	Joint torique	35	Rondelle	50	Joint torique
6	Poignée	21	Rondelle en caoutchouc	36	Pièce de connexion	51	Écrou de connexion
7	Écrou	22	Vis	37	Garniture mécanique	52	Rondelle en caoutchouc
8	Protecteur	23	Rondelle extensible	38	Joint torique	53	Corps de pompe
9	Serre-câble	24	Rondelle	39	Couvercle de chambre à huile	54	Plaque de base
10	Rondelle	25	Protecteur de ligne	40	Vis	55	Rondelle
11	Vis	26	Couvercle de moteur	41	Rondelle	56	Vis
12	Tâche	27	Protecteur thermique	42	Joint torique	57	Interrupteur à flotteur
13	Joint torique	28	Joint torique	43	Vis		
14	Vis	29	Stator	44	Joint d'étanchéité d'huile		
15	Bride	30	Rondelle ondulée	45	Roue		

5. DESPIECE SPARE PARTS PIÈCES DE RECHANGE V1100

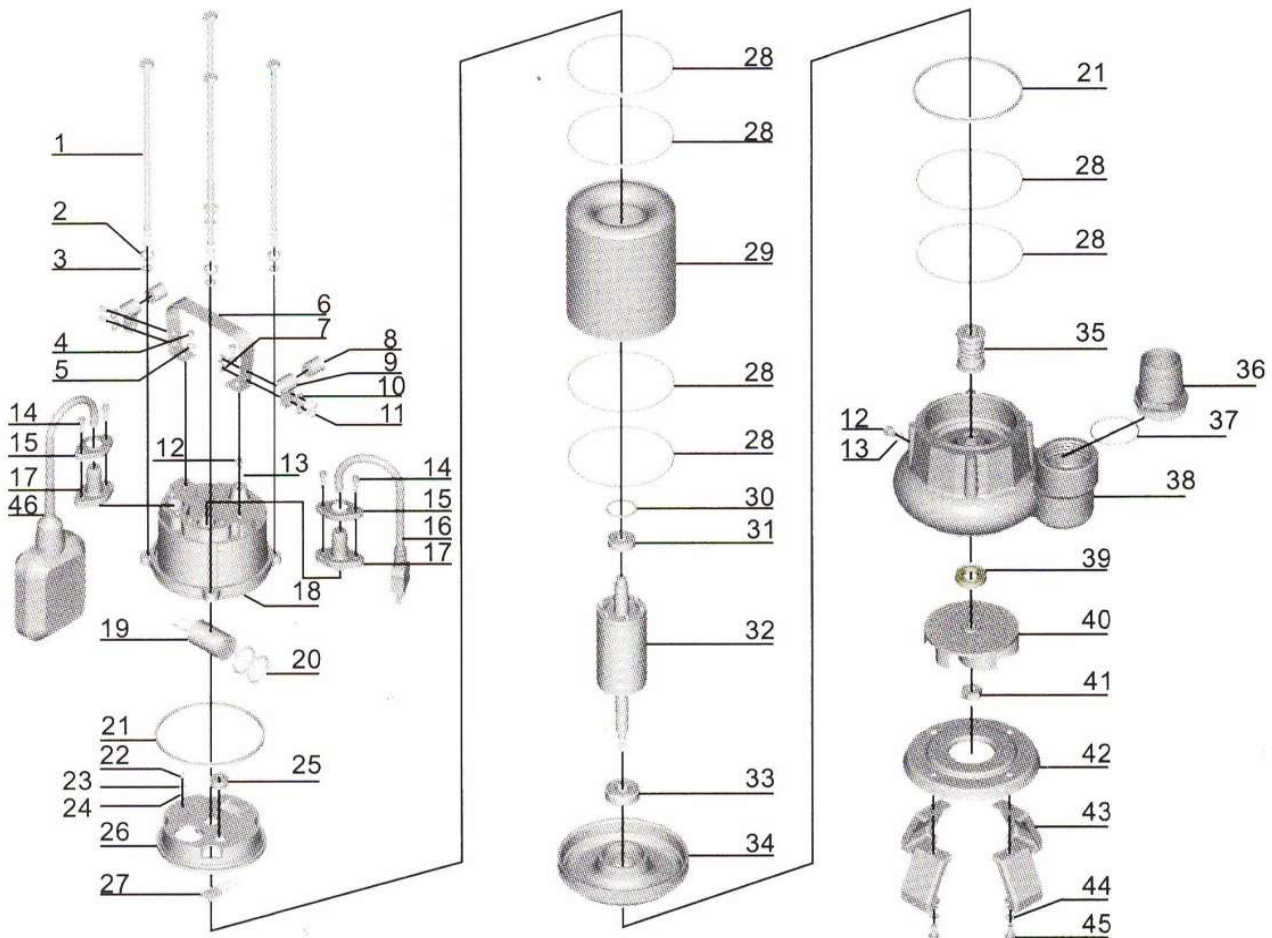

Nº	DESCRIPCIÓN	Nº	DESCRIPCIÓN	Nº	DESCRIPCIÓN	Nº	DESCRIPCIÓN
1	Barra	16	Cable	31	Rodamiento	46	Interruptor de nivel
2	Arandela extensible	17	Protector de cable	32	Rotor		
3	Arandela	18	Cobertura de cable	33	Rodamiento		
4	Barra	19	Condensador	34	Cobertura inferior		
5	Arandela	20	Anillo tórico	35	Cierre mecánico		
6	Asa	21	Arandela de goma	36	Conector de salida		
7	Tuerca	22	Tornillo	37	Anillo tórico		
8	Protector	23	Arandela extensible	38	Cuerpo de la bomba		
9	Presor de cable	24	Arandela	39	Sello de aceite		
10	Arandela	25	Protector de línea	40	Impulsor		
11	Tornillo	26	Cobertura de motor	41	Tuerca		
12	Barra	27	Protector termal	42	Cobertura de la bomba		
13	Anillo tórico	28	Anillo tórico	43	Placa base		
14	Tornillo	29	Estátor	44	Arandela		
15	Brida	30	Arandela ondulada	45	Barra		

5. DESPIECE SPARE PARTS PIÈCES DE RECHANGE V1100

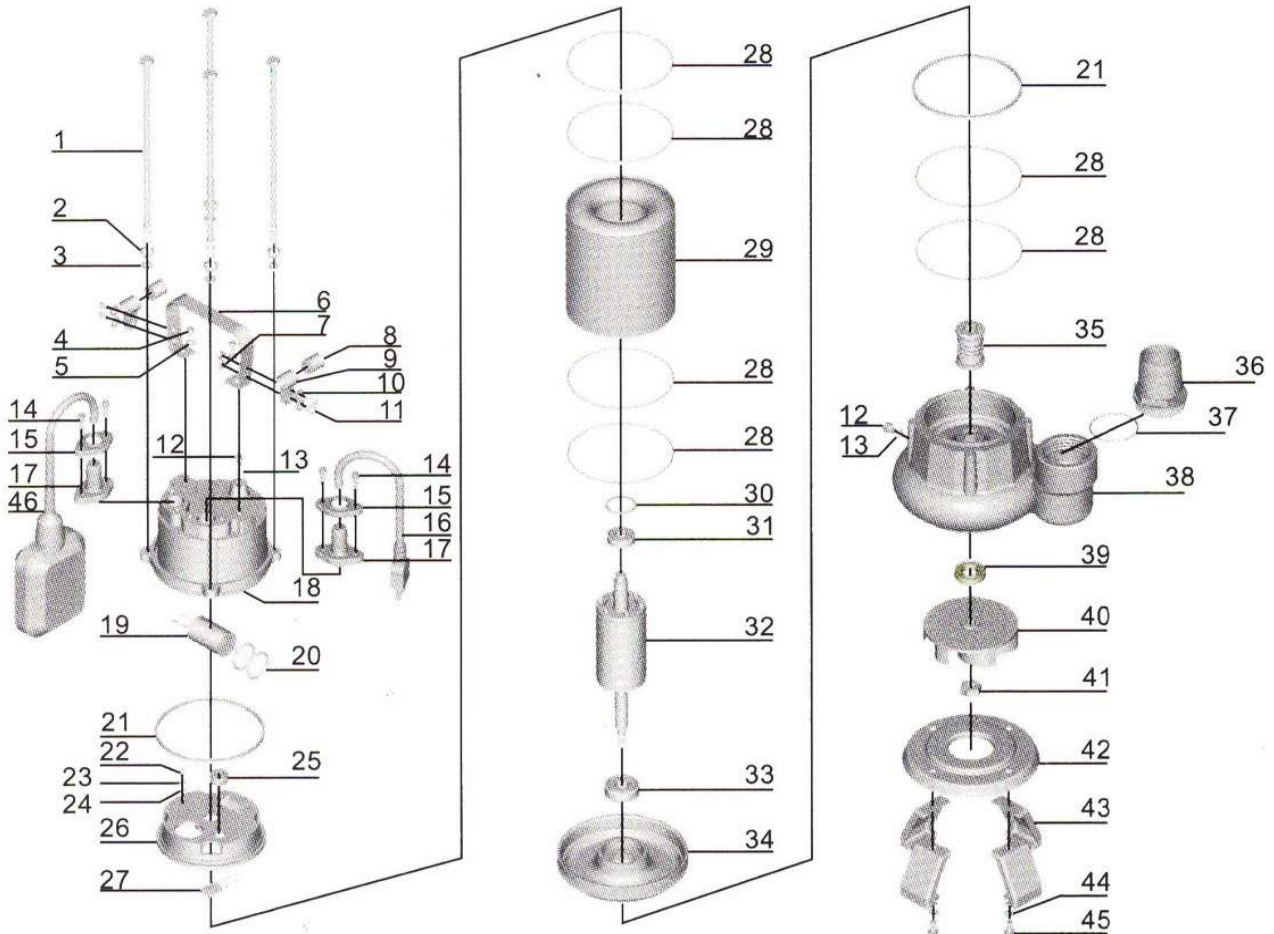

N°	DESCRIPTION	N°	DESCRIPTION	N°	DESCRIPTION	N°	DESCRIPTION
1	Blot	16	Cable	31	Bearing	46	Float switch
2	Stretching washer	17	Cable protector	32	Rotor		
3	Washer	18	Cable cover	33	Bearing		
4	Blot	19	Capacitor	34	Lower cover		
5	Washer	20	"O" ring	35	Mechanical seal		
6	Handle	21	Rubber washer	36	Outlet connector		
7	Nut	22	Screw	37	"O" ring		
8	Protector	23	Stretching washer	38	Pump body		
9	Cable presser	24	Washer	39	Oil seal		
10	Washer	25	Line protector	40	Impeller		
11	Screw	26	Motor cover	41	Nut		
12	Blot	27	Thermal protector	42	Pump cover		
13	"O" ring	28	"O" ring	43	Base plate		
14	Screw	29	Stator	44	Washer		
15	Flange	30	Undulated washer	45	Blot		

5. DESPIECE SPARE PARTS PIÈCES DE RECHANGE V1100

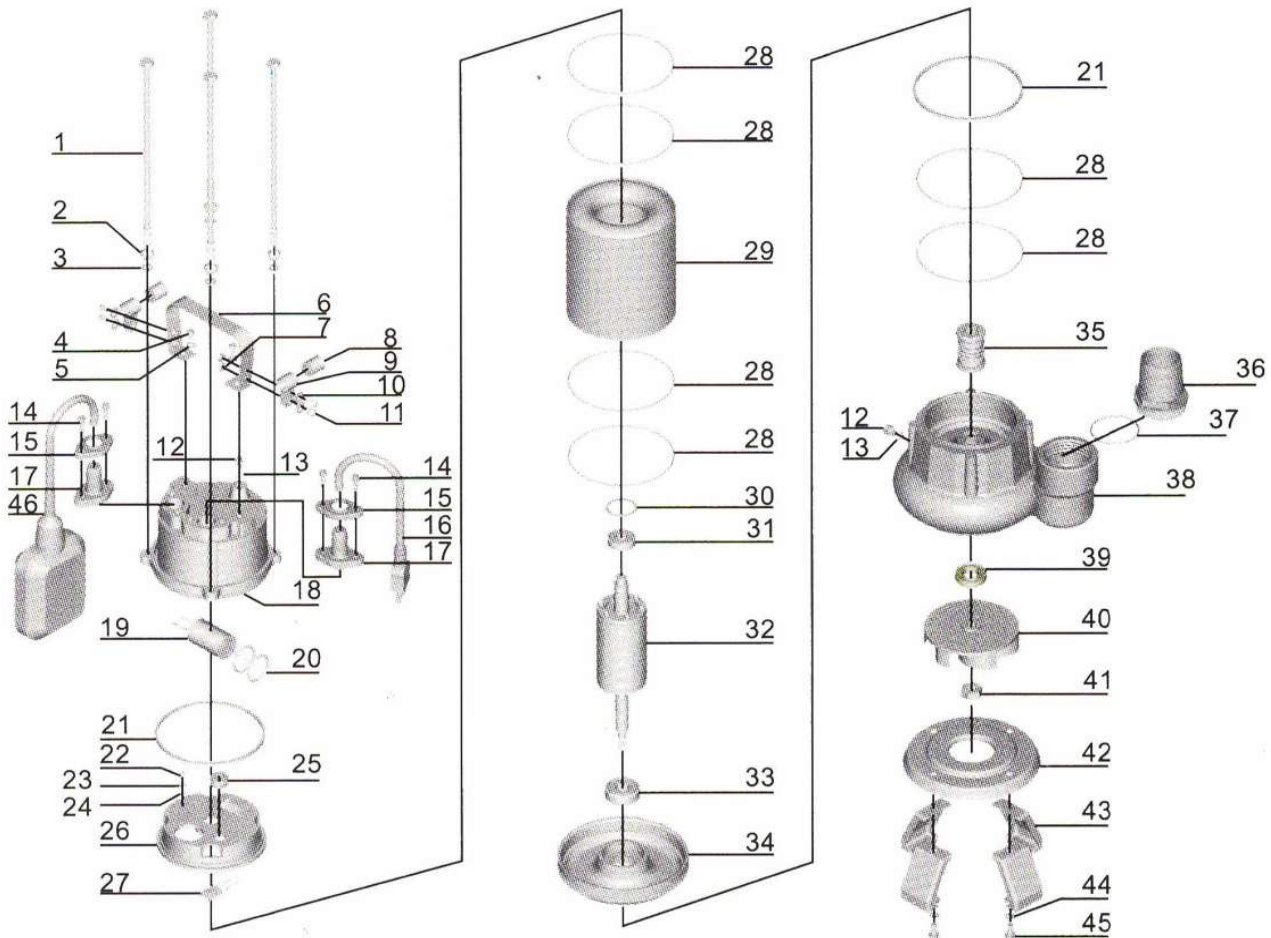

N°	DESCRIPTION	N°	DESCRIPTION	N°	DESCRIPTION	N°	DESCRIPTION
1	Tâche	16	Cable	31	Roulement	46	Interrupteur à flotteur
2	Rondelle extensible	17	Protecteur de câble	32	Rotor		
3	Rondelle	18	Couverture de câble	33	Roulement		
4	Tâche	19	Condensateur	34	Couvercle inférieur		
5	Rondelle	20	Joint torique	35	Garniture mécanique		
6	Poignée	21	Rondelle en caoutchouc	36	Connecteur de sortie		
7	Écrou	22	Vis	37	Joint torique		
8	Protecteur	23	Rondelle extensible	38	Corps de la pompe		
9	Presse-câble	24	Rondelle	39	Oil seal		
10	Rondelle	25	Protecteur de ligne	40	Roue		
11	Vis	26	Couvercle de moteur	41	Écrou		
12	Tâche	27	Thermal protecteur	42	Couvercle de pompe		
13	Joint torique	28	Joint torique	43	Plaque de base		
14	Vis	29	Stator	44	Rondelle		
15	Bride	30	Rondelle ondulée	45	Tâche		

1. DESCRIPCIÓN DESCRIPTION DESCRIPTION

Bomba de achique para uso doméstico, de construcción robusta y provista de cierre mecánico. Indicada para el vaciado de arquetas, fosas sépticas, aguas residuales, etc. Completamente de material anticorrosivo; están dotadas de inserción de latón en la boca de impulsión.

- ✦ Drain pump for home use, robust and equipped with mechanical seal construction. Suitable for emptying arquetas, septic tanks, sewage, etc. Strongly corrosive material; they are fitted with brass insert in the discharge port.

Pompe de vidange pour un usage domestique, robuste et équipé de la construction de la garniture mécanique.

- 🇫🇷 Convient pour arquetas vidange, fosse septique, assainissement, etc. Matériau fortement corrosive; ils sont équipés avec insert en laiton dans l'orifice de décharge.

V1500
V2200



MATERIALES

Cuerpo aspiración: Fundición
Cuerpo impulsión: Fundición
Impulsor: Fundición
Difusor: Fundición
Eje rotor: INOX 304
Envolvente: INOX 304
Cierre mecánico: Cer/Graf
Rejilla aspiración: INOX 304
Tornillería: INOX 304

✦ MATERIALS

Suction body: Cast iron
Discharge body: Cast iron
Impeller: Cast iron
Diffuser: Cast iron
Rotor shaft: Stainless Steel 304
Casing: Stainless Steel 304
Mechanical seal: Cer/Graf
Intake grille: Stainless Steel 304
Screws: Stainless Steel 304

🇫🇷 MATÉRIELS

Corps d'aspiration : Fonte
Corps de refoulement : Fonte
Roue : Fonte
Diffuseur : Fonte
Arbre du rotor : Acier inoxydable 304
Boîtier : Acier inoxydable 304
Garniture mécanique : Cer/Graf
Grille d'admission : Acier inoxydable 304
Vis : Acier inoxydable 304

ÁREA DE TRABAJO

Temperatura máx. del líquido: 35°C
Grado de protección: IP68
Aislamiento: F
Inmersión máx.: 5 m
Fluidos: Agua sucia

✦ WORKING RANGE

Max. liquid temperature: 35°C
Degree of protection: IP68
Insulation: F
Max. immersion: 5 m
Fluids: Dirty water

🇫🇷 PLAGUE DE TRAVAIL

Température maximale du liquide : 35°C
Degré de protection : IP68
Isolation : F
Immersion maximale : 5 m
Fluides : Eau sale

2. CURVAS CURVES COURBES

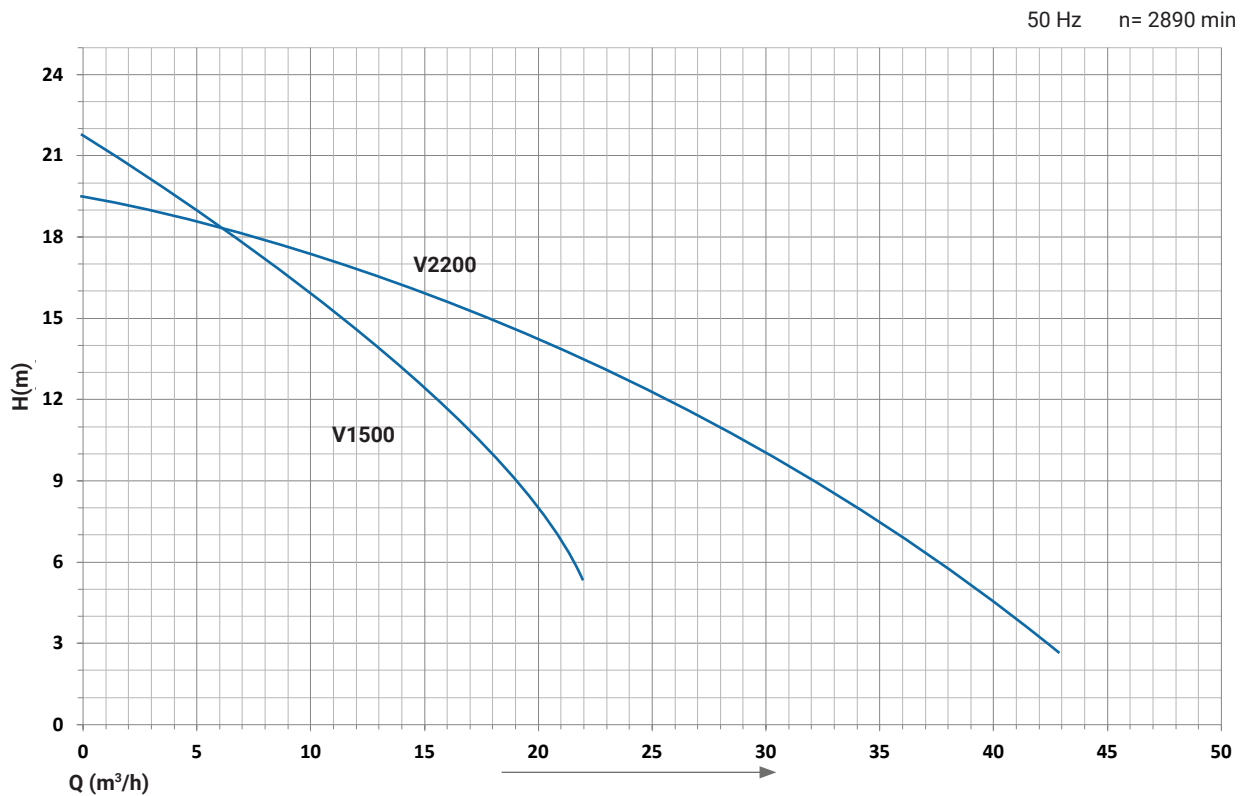

MODELO MODEL MODÈLE	CAUDAL FLOW DÉBIT											
	m³/h	0	4	8	10	15	18	22	29	35	40	43
	l/min	0	67	133	167	250	300	417	483	583	667	717
	ALTURA DE CARGA EN METROS				LOADING HEIGHT IN METRES				HAUTEUR DE CHARGEMENT EN MÈTRES			
V1500		21,7	18,5	17,5	15,7	12,3	8,9	5,3				
V2200		19,6	19	17,8	17,5	16	15,1	13,9	10,8	8,2	5,5	2,7

3. DATOS TÉCNICOS TECHNICAL DATA DONNÉES TECHNIQUES

MODELO MODEL MODÈLE	SALIDA OUTLET SORTIE [mm]	SÓLIDOS SOLIDS SOLIDES [mm]	POTENCIA (P ₂) POWER PUISSANCE		POTENCIA (P ₁) POWER PUISSANCE W	INTENSIDAD (A) CURRENT INTENSITÉ	
			KW	Hp		1~220	3~380
V1500	40	10	1,5	2,0	1.700	9,4	5,1
V2200	75	20	2,2	2,95	2.500	-	13,8

4. MEDIDAS MEASURES MESURES

V1500

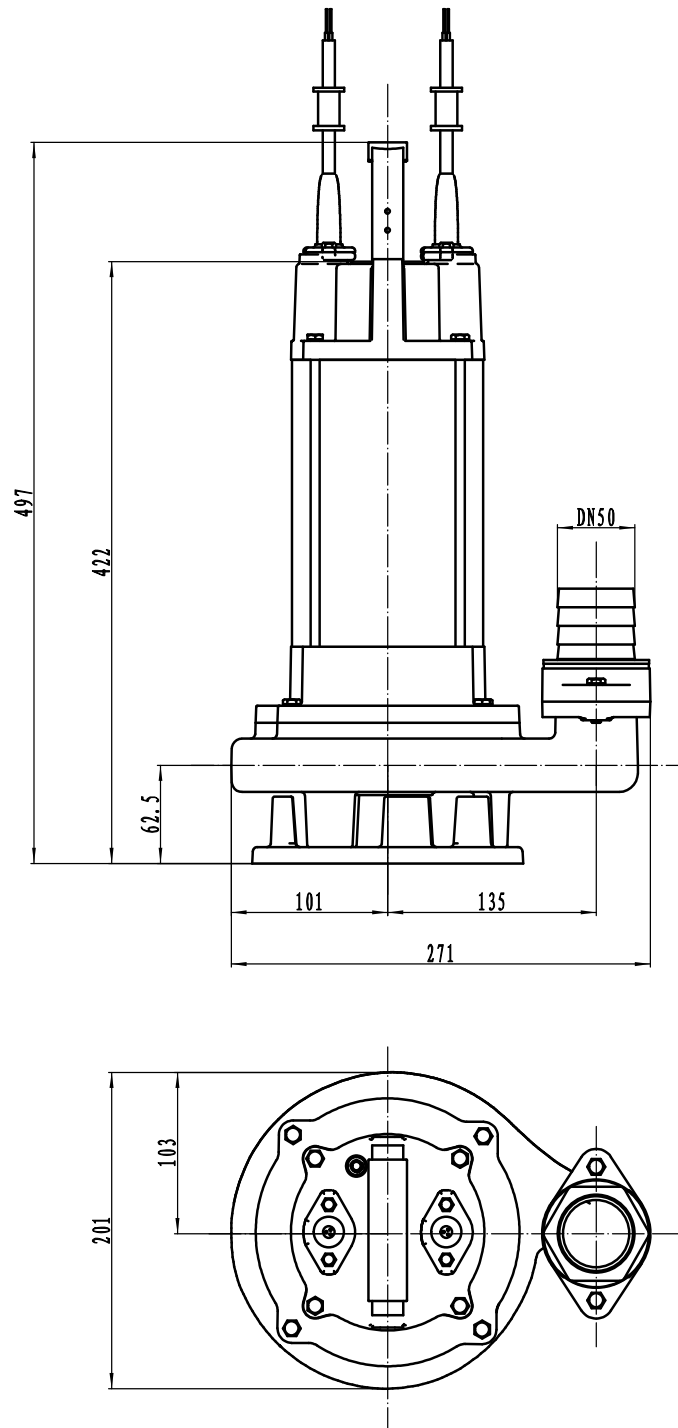

4. MEDIDAS MEASURES MESURES

V2200

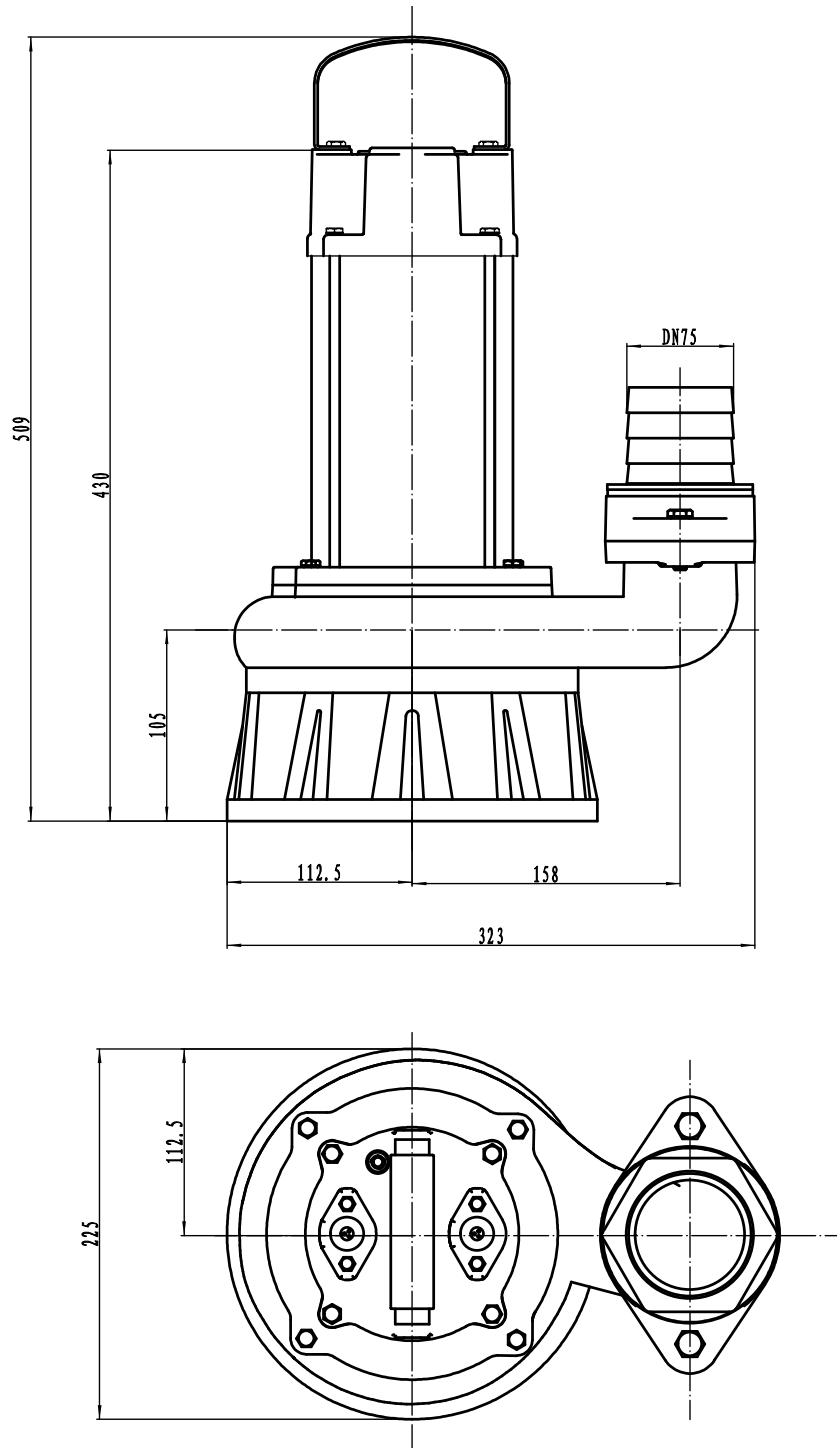

5. DESPIECE SPARE PARTS PIÈCES DE RECHANGE V1500/2200

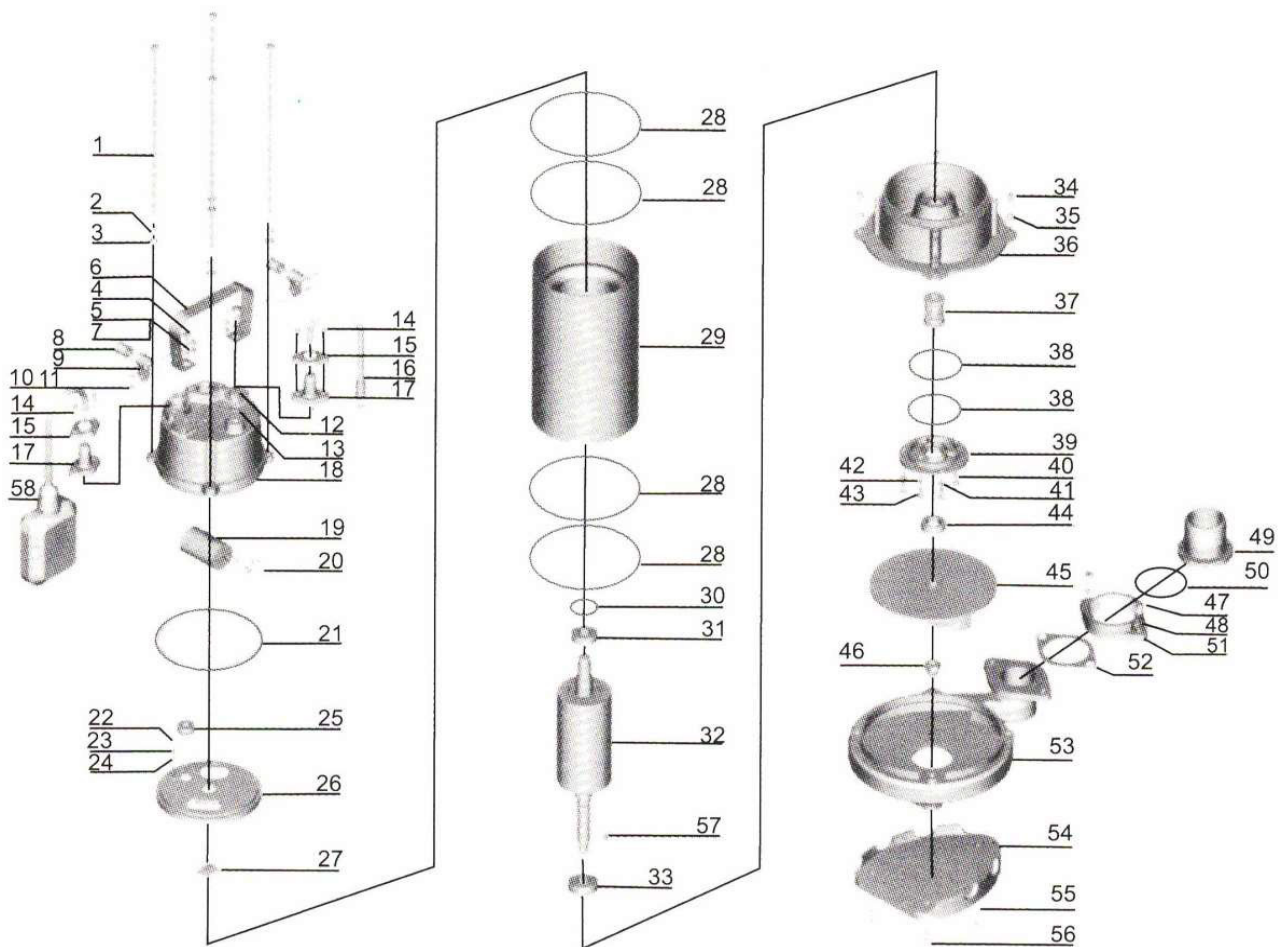

Nº	DESCRIPCIÓN	Nº	DESCRIPCIÓN	Nº	DESCRIPCIÓN	Nº	DESCRIPCIÓN
1	BARRA	16	CABLE	31	RODAMIENTO	46	TUERCA
2	ARANDELA EXTENSIBLE	17	PROTECTOR DE CABLE	32	ROTOR	47	BARRA
3	ARANDELA	18	COBERTURA DEL CABLE	33	RODAMIENTO	48	ARANDELA
4	BARRA	19	CONDENSADOR	34	TORNILLO	49	CONECTOR DE SALIDA
5	ARANDELA	20	ANILLO TÓRICO	35	ARANDELA	50	ANILLO TÓRICO
6	ASA	21	ARANDELA DE GOMA	36	PORTE DE CONEXIÓN	52	ARANDELA DE GOMA
7	TUERCA	22	TORNILLO	37	CIERRE MECÁNICO	53	CUERPO DE LA BOMBA
8	PROTECTOR	23	ARANDELA EXTENSIBLE	38	ANILLO TÓRICO	54	PLACA BASE
9	PRESOR DE CABLE	24	ARANDELA	39	COBERTURA DE LA CÁMARA DE ACEITE	55	ARANDELA
10	ARANDELA	25	PROTECTOR DE LÍNEA	40	TORNILLO	56	TORNILLO
11	TORNILLO	26	COBERTURA DEL MOTOR	41	ARANDELA	57	LLAVE
12	BARRA	27	PROTECTOR TERMAL	42	ANILLO TÓRICO	58	INTERRUPTOR DE FLOTADOR
13	ANILLO TÓRICO	28	ANILLO TÓRICO	43	TORNILLO		
14	TORNILLO	29	ESTÁTOR	44	SELLO DE ACEITE		
15	BRIDA	30	ARANDELA ONDULADA	45	IMPULSOR		

5. DESPIECE SPARE PARTS PIÈCES DE RECHANGE V1500/2200

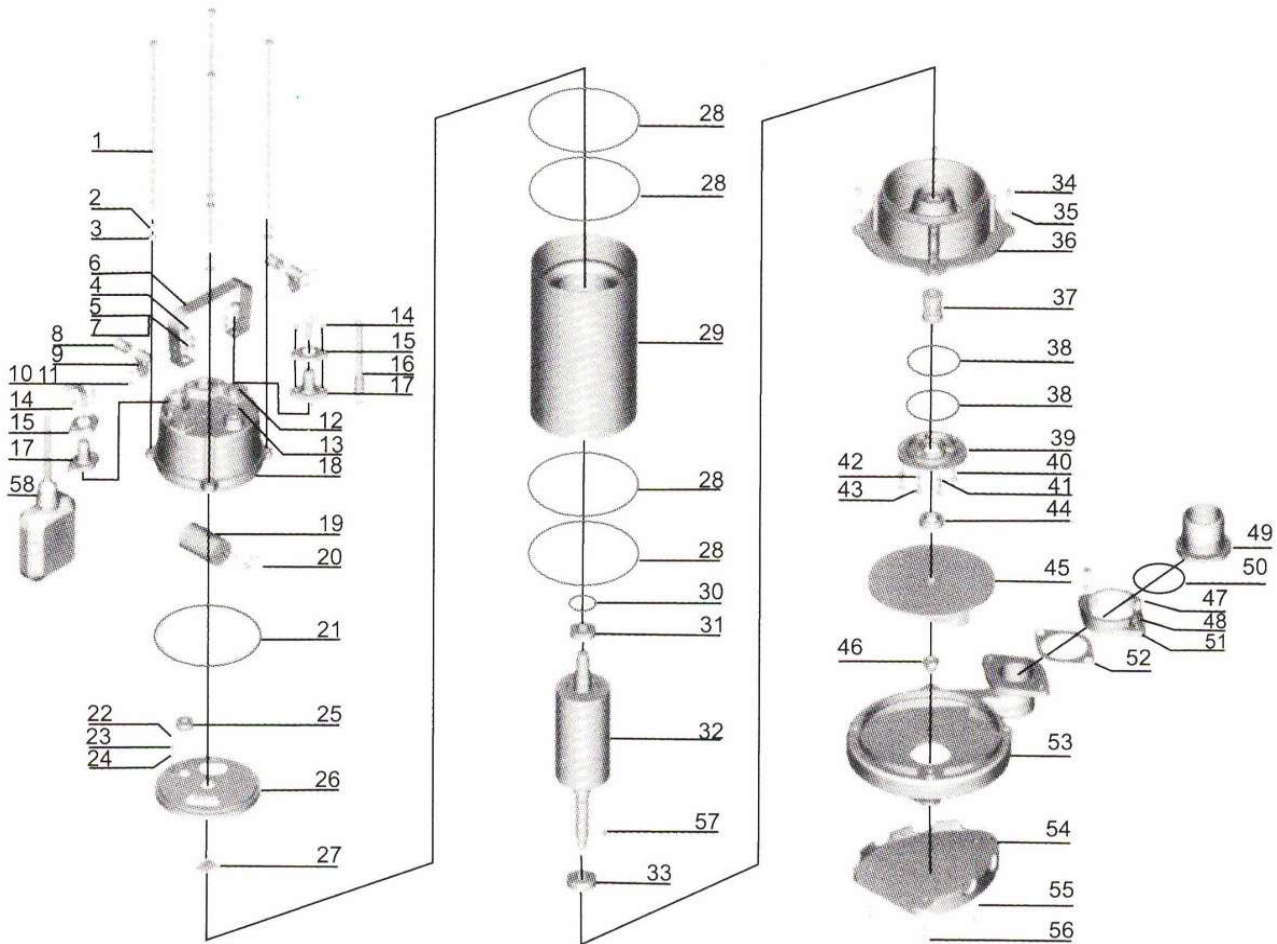

N°	DESCRIPTION	N°	DESCRIPTION	N°	DESCRIPTION	N°	DESCRIPTION
1	BLOT	16	CABLE	31	BEARING	46	NUT
2	STRETCHING WASHER	17	CABLE PROTECTOR	32	ROTOR	47	BLOT
3	WASHER	18	CABLE COVER	33	BEARING	48	WASHER
4	BLOT	19	CAPACITOR	34	SCREW	49	OUTLET CONNECTOR
5	WASHER	20	"O" RING	35	WASHER	50	"O" RING
6	HANDLE	21	RUBBER WASHER	36	CONNECTION PART	52	RUBBER WASHER
7	NUT	22	SCREW	37	MECHANICAL SEAL	53	PUMP BODY
8	PROTECTOR	23	STRETCHING WASHER	38	"O" RING	54	BASE PLATE
9	CABLE PRESSER	24	WASHER	39	OIL CHAMBER COVER	55	WASHER
10	WASHER	25	LINE PROTECTOR	40	SCREW	56	SCREW
11	SCREW	26	MOTOR COVER	41	WASHER	57	KEY
12	BLOT	27	THERMAL PROTECTOR	42	"O" RING	58	FLOAT SWITCH
13	"O" RING	28	"O" RING	43	SCREW		
14	SCREW	29	STATOR	44	OIL SEAL		
15	FLANGE	30	UNDULATED WASHER	45	IMPELLER		

5. DESPIECE SPARE PARTS PIÈCES DE RECHANGE V1500/2200

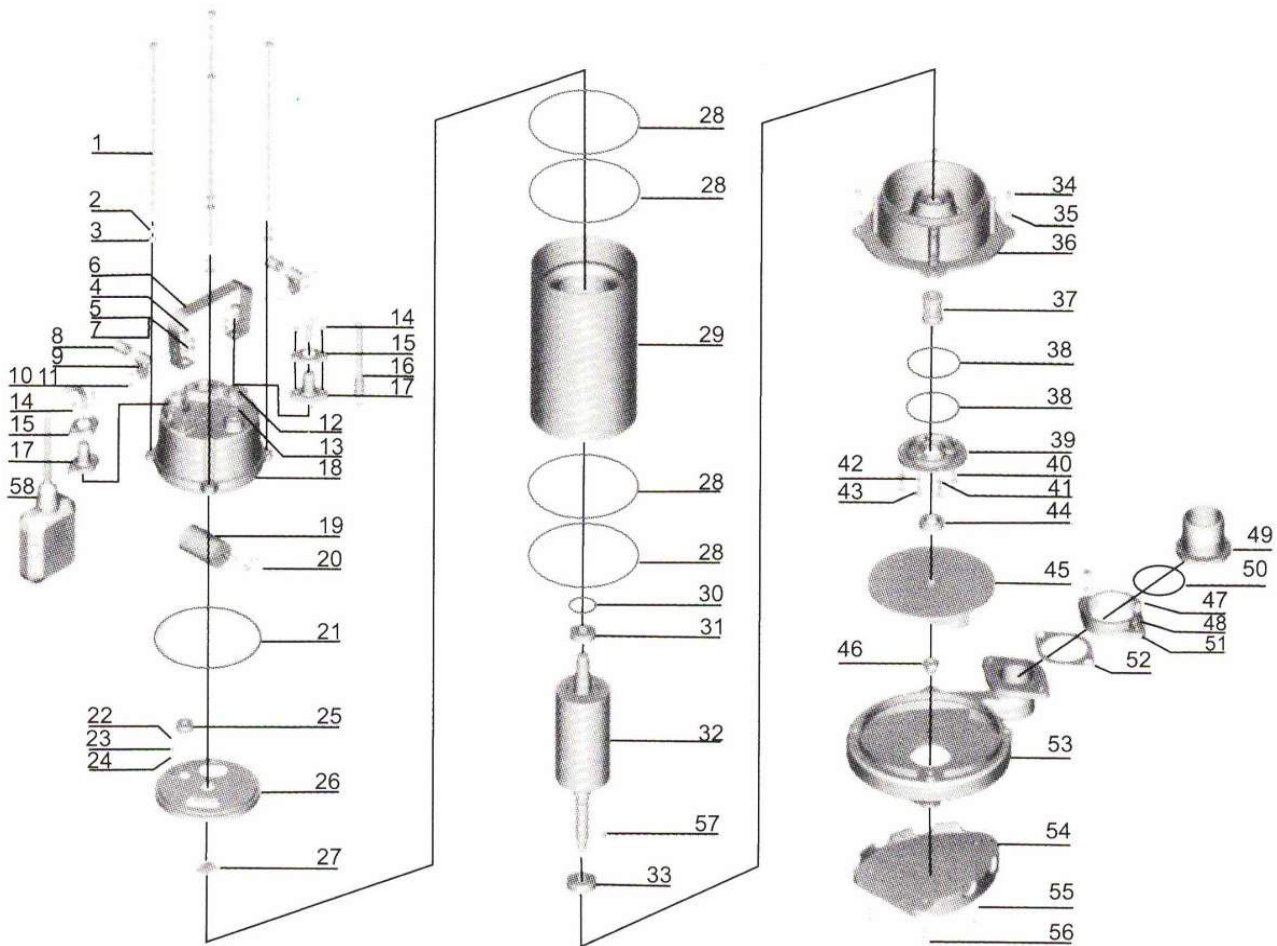

N°	DESCRIPTION	N°	DESCRIPTION	N°	DESCRIPTION	N°	DESCRIPTION
1	BLOT	16	CABLE	31	BEARING	46	NUT
2	STRETCHING WASHER	17	CABLE PROTECTOR	32	ROTOR	47	BLOT
3	WASHER	18	CABLE COVER	33	BEARING	48	WASHER
4	BLOT	19	CAPACITOR	34	SCREW	49	OUTLET CONNECTOR
5	WASHER	20	"O" RING	35	WASHER	50	"O" RING
6	HANDLE	21	RUBBER WASHER	36	CONNECTION PART	52	RUBBER WASHER
7	NUT	22	SCREW	37	MECHANICAL SEAL	53	PUMP BODY
8	PROTECTOR	23	STRETCHING WASHER	38	"O" RING	54	BASE PLATE
9	CABLE PRESSER	24	WASHER	39	OIL CHAMBER COVER	55	WASHER
10	WASHER	25	LINE PROTECTOR	40	SCREW	56	SCREW
11	SCREW	26	MOTOR COVER	41	WASHER	57	KEY
12	BLOT	27	THERMAL PROTECTOR	42	"O" RING	58	FLOAT SWITCH
13	"O" RING	28	"O" RING	43	SCREW		
14	SCREW	29	STATOR	44	OIL SEAL		
15	FLANGE	30	UNDULATED WASHER	45	IMPELLER		

5. DESPIECE SPARE PARTS PIÈCES DE RECHANGE V1500/2200

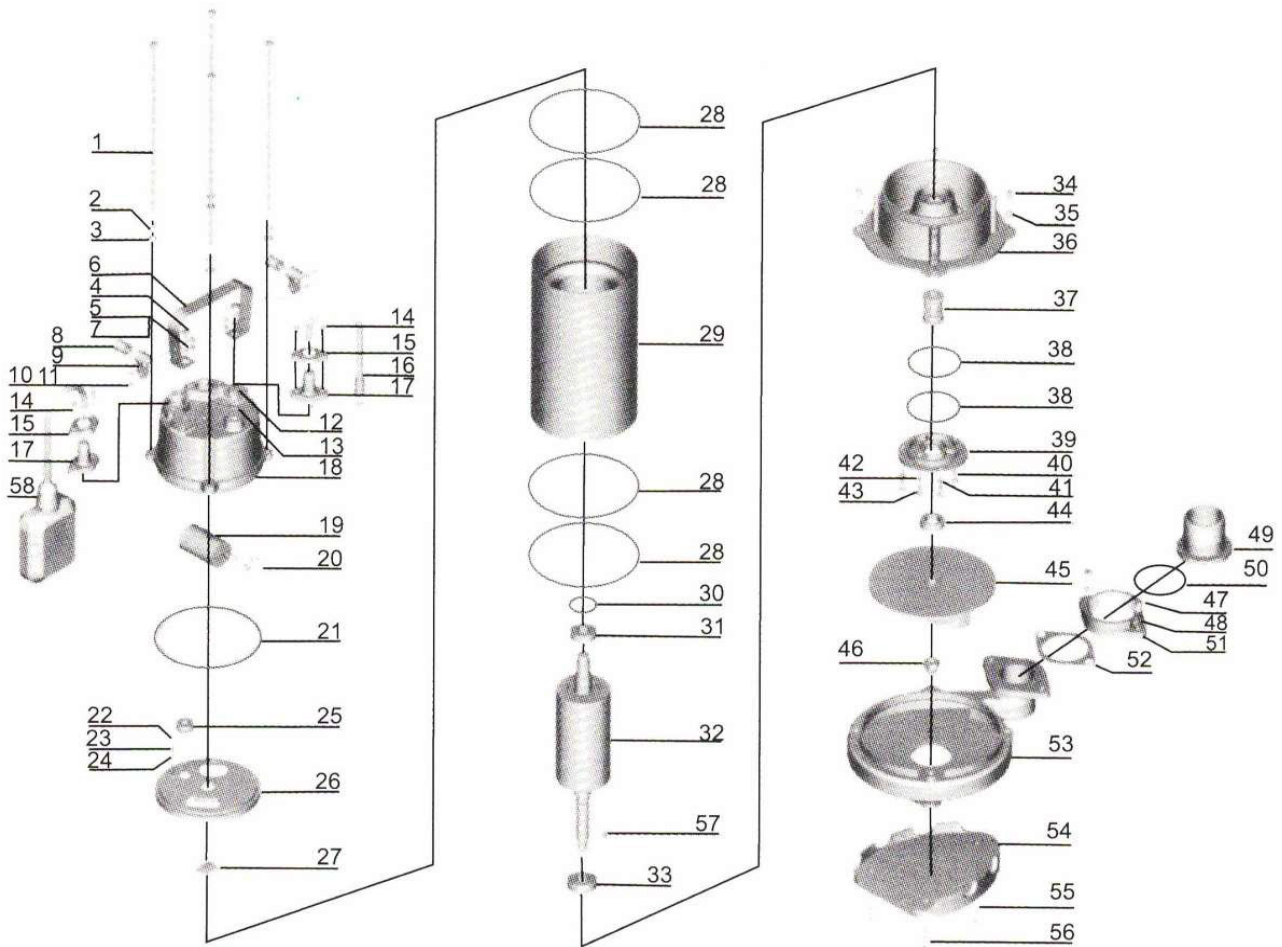

N°	DESCRIPTION	N°	DESCRIPTION	N°	DESCRIPTION	N°	DESCRIPTION
1	TÂCHE	16	CÂBLE	31	ROULEMENT	46	ÉCROU
2	RONDELLE EXTENSIBLE	17	PROTECTEUR DE CÂBLE	32	ROTOR	47	TÂCHE
3	RONDELLE	18	PROTECTION DE CÂBLE	33	ROULEMENT	48	RONDELLE
4	TÂCHE	19	CONDENSATEUR	34	VIS	49	CONNECTEUR DE SORTIE
5	RONDELLE	20	JOINT TORIQUE	35	RONDELLE	50	JOINT TORIQUE
6	POIGNÉE	21	RONDELLE EN CAOUTCHOUC	36	PARTIE DE CONNEXION	52	RONDELLE EN CAOUTCHOUC
7	ÉCROU	22	VIS	37	GARNITURE MÉCANIQUE	53	CORPS DE POMPE
8	PROTECTEUR	23	RONDELLE EXTENSIBLE	38	JOINT TORIQUE	54	PLAQUE DE BASE
9	PRESSE-CÂBLE	24	RONDELLE	39	COUVERCLE DE CHAMBRE À HUILE	55	RONDELLE
10	RONDELLE	25	PROTECTEUR DE LIGNE	40	VIS	56	VIS
11	VIS	26	COUVERCLE DE MOTEUR	41	RONDELLE	57	CLÉ
12	TÂCHE	27	THERMAL PROTECTOR	42	JOINT TORIQUE	58	INTERRUPTEUR À FLOTTEUR
13	JOINT TORIQUE	28	JOINT TORIQUE	43	VIS		
14	VIS	29	STATOR	44	JOINT D'HUILE		
15	COLLERETTE	30	RONDELLE ONDULÉE	45	ROUE		

Proindecsa

C/ Paraguay, parc. 13-5/6
Polígono industrial Oeste
30820 Alcantarilla, Murcia (Spain)

Tel. : +34 968 880 852
proindecsa@proindecsa.com

www.proindecsa.com



🇪🇸 Proindecsa S.L. no se hace responsable de los posibles errores u omisiones que pueda contener este catálogo, ni de los daños o perjuicios que puedan derivarse de su uso. Proindecsa S.L. se reserva el derecho de modificar o actualizar el contenido de este catálogo en cualquier momento y sin previo aviso.

✳️ Proindecsa S.L. shall not be liable for any errors or omissions that this catalogue may contain, nor for any damages that may arise from its use. Proindecsa S.L. reserves the right to modify or update the contents of this catalogue at any time and without prior notice.

